

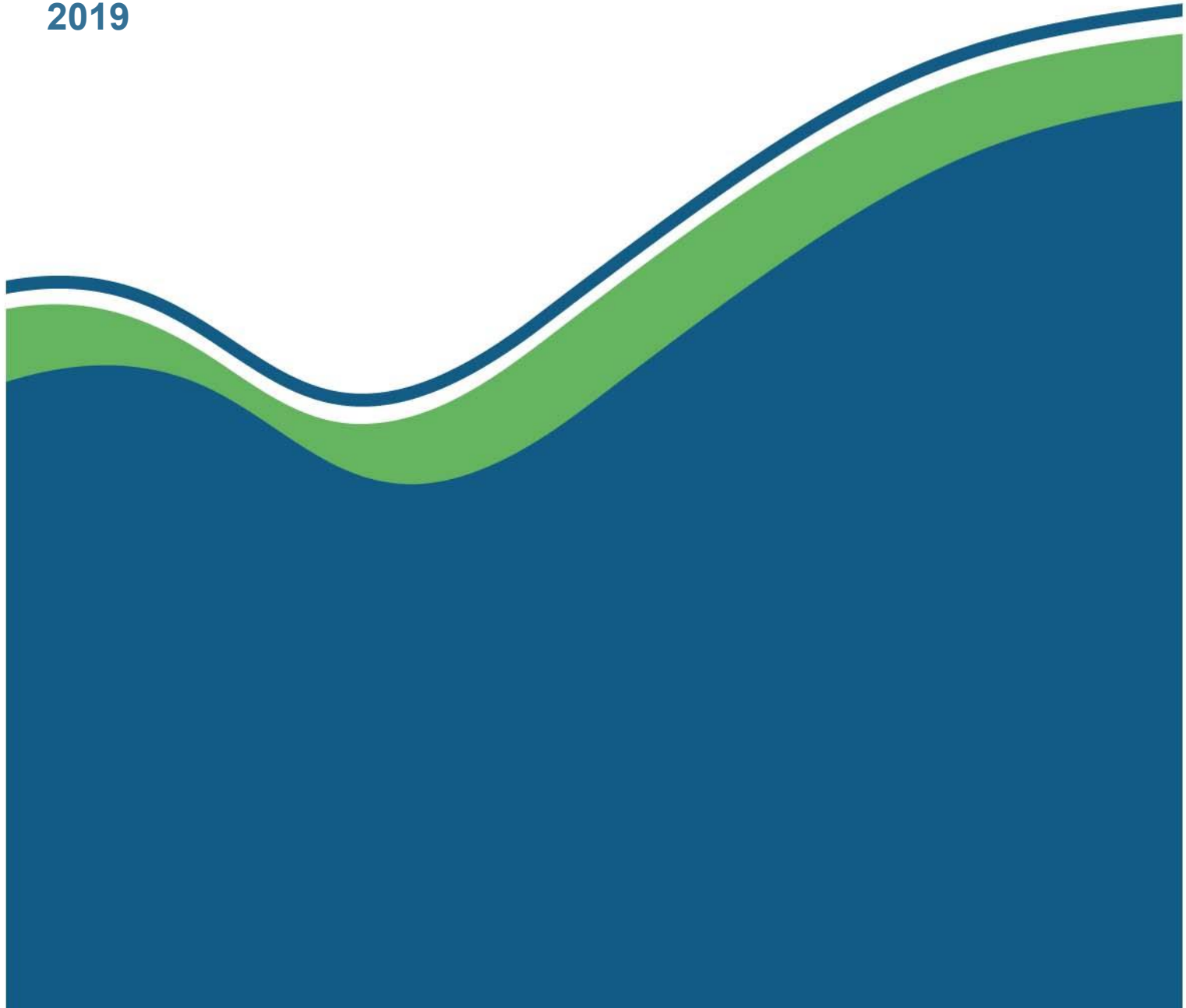

**WasteDataFlow**  
**Scotland Guidance**  
**2019**



## Table of Contents

<b>1</b>	<b>INTRODUCTION</b>	<b>5</b>
<b>2</b>	<b>CONTACTING SEPA</b>	<b>6</b>
<b>3</b>	<b>ANNUAL DATA ROLLUP</b>	<b>7</b>
<b>4</b>	<b>ONLINE VALIDATION TOOL</b>	<b>9</b>
<b>5</b>	<b>WASTE COLLECTION</b>	<b>11</b>
5.1	Question 10: Tonnes of material collected through kerbside schemes from household sources by LA or its contractors (Q)	11
5.2	Question 23: Please provide details of other waste collected for disposal (Q)	11
5.3	Question 24: How many reported fly-tipping incidents were there in your local authority? (OA)	12
5.4	Question 25: How many abandoned vehicles were disposed of by your authority and what percentage was recycled? (OA)	12
<b>6</b>	<b>WASTE MANAGEMENT (Question 100: Waste sent for treatment or disposal)</b>	<b>13</b>
6.1	Overview	13
6.2	Introduction	14
6.3	How to enter data for the first time in Q100	15
6.4	How to report outputs	19
6.5	Site-specific guidance for Q100	27
6.5.1	Residual waste sent to an incinerator.....	27
6.5.2	Residual waste sent to landfill .....	29
6.5.3	Recyclables sent to a re-processor .....	31
6.5.4	Recyclables sent to a clean Materials Recovery Facility (MRF) .....	35
6.5.5	Recyclables sent to other treatment method.....	38
6.5.6	Organic recyclables sent to a Composting Facility.....	42
6.5.7	Residual waste sent direct to Mechanical Biological Treatment (MBT), autoclave, Mechanical Heat Treatment (MHT) plant etc. ....	45
6.5.8	Residual waste sent to Refused Derived Fuel plant (RDF plant) .....	48
6.5.9	Waste sent to a residual waste materials recovery facility (dirty MRF) .....	49
6.5.10	How to report stockpiling .....	51
6.5.11	Preparing for reuse reporting.....	56
<b>7</b>	<b>SPECIFIC ISSUES</b>	<b>60</b>
7.1	Mixed waste collected for disposal that have materials extracted for recycling (Dirty MRF)	60
7.2	Tromelling/Pulverisation and other material extracted for recycling (not from kerbside, bring or CA sites)	60
7.3	Collection Rejects	60
7.4	Use of facility name “Unknown”	61
7.5	Allocation of household, Commercial and industrial Waste	63
7.6	Collecting data from waste contractors	64
7.7	How to record wood sent for recycling or recovery	65
Appendix 1. Definitions		66
Appendix 2. Typical materials that can be “prepared for reuse”		67
Appendix 3. Household Waste Statistics		68

## List of Tables

Table 1. How to report waste inputs and outputs in Q100	23
Table 2: How to report incinerator outputs	27
Table 3: How to report reuse and reprocessor outputs	33
Table 4: How to report clean MRF outputs	36
Table 5. How to report MBT outputs	45
Table 6. How to report waste outputs FROM “Stockpile Use”	54
Table 7. Examples of the processes involved in preparing for reuse and recycling for specific materials	57
Table 8. WasteDataFlow waste categories, associated waste source and applicable targets	64
Table 9. Typical materials that can be prepared for reuse	67
Table 10. Statistical waste categories	68

## List of Figures

Figure 1. Data roll up screen	7
Figure 2. An example roll-up queue for roll up of annual data	7
Figure 3. Data authorisation screen – quarterly submission	8
Figure 4. Data authorisation screen – annual submission	8
Figure 5. To enter waste sent to a treatment facility at the top level of the tree, click on Q100 and enter the details in the <i>Waste Details</i> section	16
Figure 6. Waste type list for a new Output. In this instance the waste type list is for an output from Other Method.	20
Figure 7. <i>Facility Type</i> for a new Output.	21
Figure 8. Flow chart depicting waste sent direct to incineration and Q100 tree structure	28
Figure 9. Flow chart depicting waste sent direct to landfill and Q100 tree structure	30
Figure 10. To record waste recycled or reused, in the Waste Details section choose one of the Recycling or Reuse facility types	31
Figure 11. For recycling and reuse facility types, choose Source segregated recyclate as the Waste Stream.	32
Figure 12. Use the Auto FD facility to mark the recycling or reuse facility as an end destination.	33
Figure 13. Flow chart depicting waste sent direct to reprocessor and Q100 tree structure	34
Figure 14. To record source segregated mixed materials sent to a MRF for separation, in the Waste Details section choose Materials recovery facility.	35
Figure 15. For MRF facility use the default Waste Stream of Comingled recyclate.	36
Figure 16. Flow chart depicting waste sent to clean MRF and Q100 tree structure	37
Figure 17. Other Method can uniquely take either <i>Residual Waste</i> or <i>Source segregated recyclate</i> for Waste Stream.	38
Figure 18. Flow chart showing Street Sweepings sent for treatment and Q100 tree structure	40
Figure 19. Flow chart showing WEEE sent for treatment and Q100 tree structure	41
Figure 20. Choose the “Final Destination – PAS Compliant” to record PAS compliant compost outputs	43
Figure 21. Flow chart showing waste sent for composting and Q100 tree structure	44
Figure 22. Flow chart showing waste sent to MBT and Q100 tree structure	46
Figure 23. Depiction of residual waste sent to an RDF plant for sorting high calorific waste prior to incineration	48
Figure 24. A depiction of residual waste sent to a dirty MRF and Q100 tree structure.	50
Figure 25. Example question 100 tree for use of stockpiled material	52
Figure 26. Example of collection rejects in the collection questions	60
Figure 27. Waste stream type of rejects from collection	61

# 1 INTRODUCTION

WasteDataFlow is a data collection tool used by all Scottish Local Authorities' (LA's) to record its waste collected and managed. It is the primary source of household and municipal waste data used to record the progress of recycling and waste management under Scotland's [Making Things Last – A Circular Economy Strategy for Scotland](#). The data is also used for reporting to the EU in accordance with the Waste Statistics Regulations and Waste Framework Directive,.

The guidance is separated into six sections:

- **Annual data rollup:** identifies how to submit annual data from quarterly datasets where the data is entered quarterly or annually.
- **[Online validation tool:](#)** provides a visual analysis of waste generated and managed for Scottish WasteDataFlow (WDF) returns providing a summary of submitted data, a series of validation checks, and summary reports.
- **Collection questions:** these questions are about the waste collected in each quarter/year.
- **Management questions:** this comprises one question – question 100. The interface is a graphical management tree that depicts the flow of collected waste through different management methods.
- **WasteDataFlow User Tips:** provides some general tips about data entry.
- **Specific Issues:** provides some details about common specific issues.

## 2 CONTACTING SEPA

Please contact SEPA at [wastedata.flow@sepa.org.uk](mailto:wastedata.flow@sepa.org.uk) for further help or advice about:

- how to enter data correctly
- queries about this guidance
- queries about the Online validation tool,
- requests to roll down data,
- requests to add a new facility to the WDF system
- requests to add a new user in your authority to the WDF system
- to provide SEPA staff with updates for primary and secondary WDF users and head of department contacts in your authority

Please contact the WasteDataFlow help desk at [helpdesk@wastedataflow.org](mailto:helpdesk@wastedataflow.org) or 0845 6000 890 for technical or system issues such as:

- inability to log into WDF
- problem with rolling data up or down

### 3 ANNUAL DATA ROLLUP

Local Authorities are given the choice of entering and validating data in WasteDataFlow either monthly, quarterly or annually and WasteDataFlow includes a mechanism to produce annual data from this.

The data verification and reporting process undertaken by SEPA is done on an annual basis only.

A screen shot of the roll-up page is depicted in Figure 1 below. The quarterly data is located at the upper half of the screen. A new section at the lower half of the screen comprises an annual period.

#### Data roll up

- **Clicking on the “Rollup Data” link associated with the annual period will place five sets of data into the roll-up queue.**
- Each quarter for the year is placed into the roll-up queue that is Jan-Mar, Apr-Jun, Jul-Sep and Oct-Dec
- A Jan-Dec period is added to the queue. On successful completion of the roll-up, the Jan-Dec period will contain data aggregated over the four quarters.

The final result is that a calendar year dataset is available in the data authorisation page.

An example of the roll-up queue generated as a result of rolling up data associated with the annual period is depicted in Figure 2 below. In this figure, the annual period is circled in red.

**Figure 1. Data roll up screen**

Number of Incomplete Questions								
Oct 13 - Dec 13	0	<a href="#">Rollup Data</a>	Oct 13	16	Nov 13	16	Dec 13	0
Jul 13 - Sep 13	0	<a href="#">Rollup Data</a>	Jul 13	16	Aug 13	15	Sep 13	0
Apr 13 - Jun 13	0	<a href="#">Rollup Data</a>	Apr 13	16	May 13	16	Jun 13	0
Jan 13 - Mar 13	0	<a href="#">Rollup Data</a>	Jan 13	41	Feb 13	41	Mar 13	0
Period	Total							
Jan 14 - Dec 14	0							
Jan 13 - Dec 13	0			<a href="#">Rollup Data</a>				
Jan 12 - Dec 12	0			<a href="#">Rollup Data</a>				
Apr 08 - Mar 09	0			<a href="#">Rollup Data</a>				

**Figure 2. An example roll-up queue for roll up of annual data**





Rollup Job Queue			
Authority	Period	Queued	
1 Aberdeen City	Jan 13 - Mar 13	27/05/2014 10:58:18	
2 Aberdeen City	Apr 13 - Jun 13	27/05/2014 10:58:18	
3 Aberdeen City	Jul 13 - Sep 13	27/05/2014 10:58:18	
4 Aberdeen City	Oct 13 - Dec 13	27/05/2014 10:58:18	
5 Aberdeen City	Jan 13 - Dec 13	27/05/2014 10:58:18	<a href="#">Cancel Job</a>

### Quarterly data entry

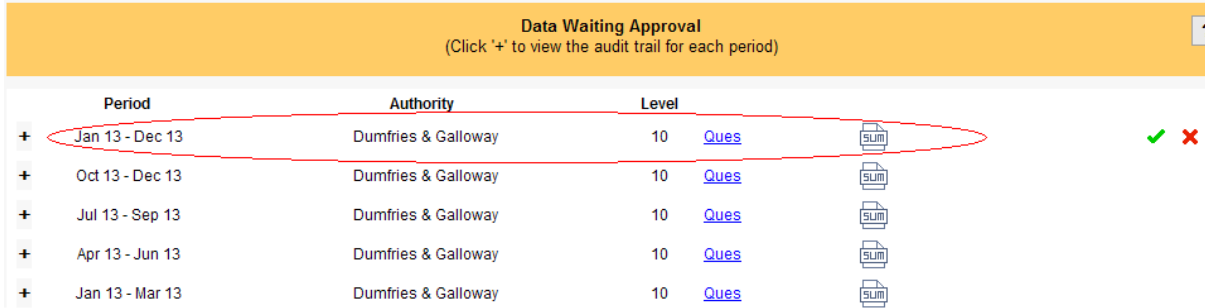
If you enter data quarterly, the result will be that all four quarters are rolled up (Jan-Mar, Apr-Jun, Jul-Sep, and Oct-Dec), and an additional calendar year aggregate of the four quarters is also rolled up (Jan-Dec). These five rolled up datasets are available in the data authorisation page and is available for viewing in the validation tool as normal. Please refer to *Figure 3* below.

**Figure 3. Data authorisation screen – quarterly submission**





Data Waiting Approval						
(Click '+' to view the audit trail for each period)						
Period	Authority	Level				
+ Jan 13 - Dec 13	Dumfries & Galloway	10	<a href="#">Ques</a>			✓ ✗
+ Oct 13 - Dec 13	Dumfries & Galloway	10	<a href="#">Ques</a>			
+ Jul 13 - Sep 13	Dumfries & Galloway	10	<a href="#">Ques</a>			
+ Apr 13 - Jun 13	Dumfries & Galloway	10	<a href="#">Ques</a>			
+ Jan 13 - Mar 13	Dumfries & Galloway	10	<a href="#">Ques</a>			

### Annual data entry

If you enter data annually, the first three quarters will be automatically “excluded” from the roll-up process. The result of your roll-up will be one quarter of rolled up data (Oct-Dec) and one calendar year of data in the data authorisation page, and three quarters of excluded data (Jan-Mar, Apr-Jun, Jul-Sep). Please refer to *Figure 4* below.

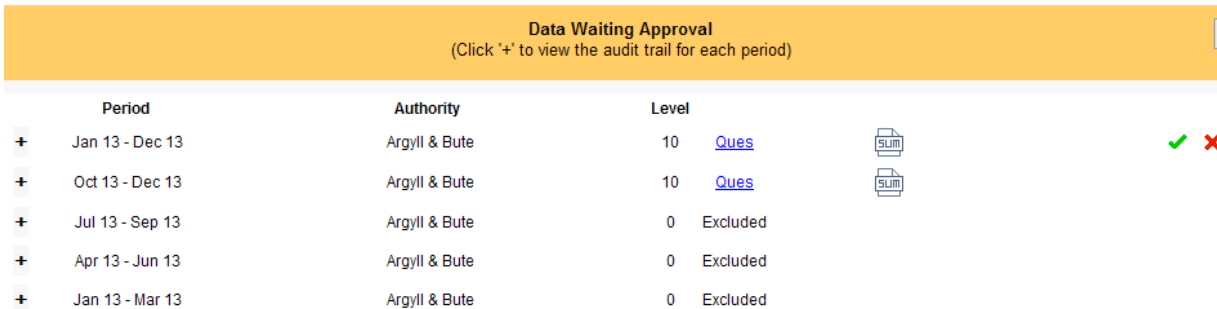
**Figure 4. Data authorisation screen – annual submission**



Data Waiting Approval						
(Click '+' to view the audit trail for each period)						
Period	Authority	Level				
+ Jan 13 - Dec 13	Argyll & Bute	10	<a href="#">Ques</a>			✓ ✗
+ Oct 13 - Dec 13	Argyll & Bute	10	<a href="#">Ques</a>			
+ Jul 13 - Sep 13	Argyll & Bute	0	Excluded			
+ Apr 13 - Jun 13	Argyll & Bute	0	Excluded			
+ Jan 13 - Mar 13	Argyll & Bute	0	Excluded			

### Routine data roll-up and roll-down

Irrespective of whether data is entered quarterly or annually, you can roll-up quarterly/annually data to level 10 on a quarter by quarter basis to enable viewing of quarterly/annually data in the on-line validation tool.

### Annual Reconciliation

The on-line validation tool contains an annual reconciliation of data entered for the calendar year. This includes previous years comparison of recycling rates and material arisings and management. It also includes a preview of annual statistical data that will be published by SEPA. *Please note that the annual reconciliation is only visible for the Jan-Dec calendar year data.*



## 4 ONLINE VALIDATION TOOL

The Scotland WasteDataFlow Summary and Validation application provides a visual analysis of waste generated and managed for Scottish WasteDataFlow (WDF) returns for use by Scottish local authorities. It provides a summary of submitted data, a series of validation checks, and summary reports.

The link for the tool is: <https://informatics.sepa.org.uk/data-visualisation/sepa/wastedataflow/>

To use the tool, click on the above link or copy and paste the link into a web browser (e.g. internet explorer, firefox, etc.). When the tool first launches it will prompt for a username and password. Enter the following details:

**Username:** your WasteDataFlow login username

**Password:** your WasteDataFlow login password

The tool takes about 45 seconds to load. Once loaded however, it is fairly quick to move around the various visualisations and viewing quarterly or annual data back to 2013. For the current verification year, the tool retrieves live data from the WasteDataFlow web site, allowing local authority users can refresh and view the data as soon as the WasteDataFlow data has been rolled up to level 10 or higher.

The launch page is the "Help" page, which explains the layout of the tool. The "About" page provides more details about the various checks and reports.

The tool comprises a series of checks and identifies where and why checks may be flagged, these are:

- **Difference in waste collected and managed-** Provides a summary of difference in tonnes of waste collected and waste managed in the quarter/year.
- **Source Split-** Checks that the sum of household, commercial and industrial tonnes entered is equal to total tonnes entered for primary facilities in Q100.
- **Input Materials** - Checks that the materials entered as inputs to a facility is consistent with the material expected for that type of facility
- **Output Facilities** - Checks that outputs are to a facility expected for the type of waste management (e.g. incinerator bottom ash output / metals is only expected as outputs from incineration)
- **Output Waste Type:** Checks that the Output Waste Type has been entered for the waste outputs
- **Facility Inputs Minus Outputs:** Checks that the outputs from a facility are equal to the inputs for the following facility types: MRF, Residual MRF, RDF.
- **Kerbside Check:** Checks that inputs of materials to top-level facilities in Q100 is greater than or equal to household kerbside waste recorded as collected in Q10.
- **Residual Check:** Checks that inputs to top-level facilities in Q100 is the same as the waste recorded in collection question Q23.
- **MRF Rejects:** Checks that the percentage rejects from MRFs is within the expected range.
- **Incineration outputs:** Checks that the percentage outputs from incinerators is within the expected range.
- **Other materials:** Checks that a description has been provided when the material category recorded is "Other Materials"
- **Reprocessor multiple materials:** Flags where more than one DMR material group has been sent to the same facility for recycling.

**Please ensure that ALL checks are OK in the checks summary page before submitting your return<sup>1</sup>.**

---

<sup>1</sup> For the *Verification* section on the lower half of the page, flagging of a check may be allowable under some circumstances with prior agreement. Please ensure Comments are added explaining why the check is flagged.

The tool also provides standard annual reports about household waste statistics from the WDF returns:

- **Recycling Statistics** - provides information about rates of household recycling, landfilling, and other diversion (annual data only)
- **Household Data Tables** - a summary of data by statistical reporting category (annual data only)
- **Previous Year Comparison** - provides a comparison of waste managed by reporting category against the previous years (annual data only)
- **BMW Landfilled**- provides a summary of biodegradable municipal waste (BMW) landfilled (annual and quarterly data).

## 5 WASTE COLLECTION

There are four collection questions (questions 10, 23, 24-25). The household kerbside collected waste (Q10) and residual waste collected (question 23) should be filled out either quarterly or annually. However, the fly-tipping and abandoned vehicles questions (questions 24-25) should only be entered annually.

**Waste collection should be recorded in the same period that the waste is managed.** For example, if waste is collected in December 2018, and kept in storage at a transfer station until sent for waste treatment in January 2019, the collection should be recorded in the Jan – Dec 2019 period. This allows the waste collection and waste managed to balance for the period.

### 5.1 Question 10: Tonnes of material collected through kerbside schemes from household sources by LA or its contractors (Q)

For each material listed, enter the quantities that are collected by or on behalf of your authority from households for recycling/composting; the quantity collected for recycling/composting but actually disposed; the number of households receiving a collection; the quantity collected for reuse and the quantity collected for reuse but actually disposed. Also indicate if the material is collected co-mingled.

Please note that the tonnage of material sent to a clean MRF or Sorting Facility for recycling but which are subsequently disposed of should be reported in Question 100.

- Detailed information on the wastes to be included under household waste sources is provided in the Extra Guidance section of this guidance.
- Use mixed glass if no colour breakdown; rubble denotes hardcore and bricks; vegetable oil denotes cooking oil
- If any NON BIODEGRADABLE materials are not listed, please enter the tonnage in the 'Other Materials' box. If any BIODEGRADABLE materials are not listed, please enter the tonnage in the 'Other Compostable Waste' box. If the materials are partially biodegradable please allocate the tonnage in these two sections accordingly. Please also give a tonnage breakdown of 'Other Materials' in the comments box as there may be more than one type of materials.

### 5.2 Question 23: Please provide details of other waste collected for disposal (Q)

Enter the quantity of waste collected for disposal by or on behalf of your authority for each method listed and the percentage weighed.

- This also includes mixed waste subsequently sent to a dirty MRF or MBT plant. Scottish Local Authorities **do not need to input the destination of the residual waste** for each type of waste. Include waste collected in the authority for disposal WITHIN the authority boundaries and waste collected in the authority for disposal OUTSIDE authority boundaries. Do not include waste separately collected for reuse, recycling and composting, this is dealt with in the collected for recycling/composting questions.
- If any other waste type is not listed, please enter the tonnages in the relevant 'other' box and give a breakdown in the comments box.

For details about the Q23 waste categories, and how they are interpreted for household waste statistical reporting and waste targets, please refer to Table 8 on page 64.

**5.3 Question 24: How many reported fly-tipping incidents were there in your local authority? (OA)**

Enter the number of fly-tipping incidents reported directly to your authority or reported by your authority through the 'Dumb Dumpers' website.

**5.4 Question 25: How many abandoned vehicles were disposed of by your authority and what percentage was recycled? (OA)**

Enter the number and tonnages of abandoned or end of life vehicles that were handled by or on behalf of your authority; the tonnage can be estimated by multiplying the number of vehicles uplifted by 0.98. Please also indicate the percentage recycled by the dismantler.

## 6 WASTE MANAGEMENT (Question 100: Waste sent for treatment or disposal)

### Overview

The following guidance is to help local authorities enter data using Q100 on WasteDataFlow. The guidance is split into the following sections:

- Introduction to Q100
  - the advantages of the question layout
  - an overview of the screen layout
- Important general tips – please read before going any further
- General advice on entering data for the first time in Q100
  - selecting management methods and waste input types
  - reporting household, commercial and industrial splits
  - entering waste material types, transfer stations and additional comments
  - reporting waste outputs and the final end use of waste
- Loading previous tree structures
- Site-specific help and advice for the following management types:
  - Incinerators
  - Landfill
  - Re-processors
  - Materials recovery facilities (MRF)
  - Composting
  - Mechanical biological treatment (MBT)
  - Residual waste materials recovery facilities (dirty MRF)
- Example waste movement trees for the following site types:
  - Landfill, Residual waste MRF, Composting plant, MBT plant

## 6.1 Introduction

Q100 records all waste sent for treatment or disposal. The advantages of using this layout is:

- Q100 enables you to report how all waste is managed within a single question
- Outputs from one facility can be recorded as inputs to another facility
- You can enter data in broadly the same way for quite different management methods
- Data can be more easily viewed and reconciled on WasteDataFlow using the “Waste movement tree”

Question 100 screen has four sections:





- *The Waste Movement Tree* is on the left-hand side of the screen and is used to build up a picture of how individual waste types are managed. You also use the tree to navigate between different waste types when you are entering data in the waste details section
- *The Waste Details* section, underneath the Waste Movement Tree on the lower left-hand side, is used to:
  - Enter the type of facility and name of facility where the waste is sent.
  - Enter the total tonnes of waste sent to the facility (not required for some facility types)
  - Enter the waste stream type (for facility types this is pre-loaded)
- The *Materials* section on the lower middle section of the screen is available to enter the type of material sent to a facility.
- The *Sources / Comments / Transfer Stations* section on the lower right of the screen is available at every level of the “tree” and is used to enter information on tonnages, materials, household / commercial / industrial splits and transfer stations for a given waste type.
  - Sources: Use this section to enter information on tonnages, materials, household / commercial / industrial splits. This is only available when the facility is a primary facility, that is a facility at the top level of the Q100 tree
  - Comments: Enter any comments here that will help SEPA staff to understand the nature of the type of waste or how the waste has been managed
  - List the transfer stations used to store waste before being sent for treatment.

**Do not enter transfer stations used for the sole purpose of waste transfer into the Waste Movement Tree. Only enter a facility into the tree where waste is treated.**

All the above are used during data entry and it is important to understand how they work before entering data in Q100.

## The coloured symbols in the waste movement tree

A legend for the coloured symbols available in the waste movement tree can be found below

-  This is a 'top-level' node that should have some outputs or be confirmed as a final destination, so may be a primary treatment facility or a re-processor/reuse
-  This is a 'sub-level' node that should have some outputs or be confirmed as a final destination, so may be a secondary or tertiary treatment facility or a re-processor/reuse
-  This is an end node where waste has been confirmed as being recycled, reused or composted. So would be found under these facility types.
-  This is an end node where waste has been landfilled so would be found where any waste is reported as going to any kind of landfill.
-  This is a warning node to let you know that you have added a Facility or Process Type that WasteDataFlow expects to have some sub level outputs.

## General tips – please read before going any further

**Entering data for the first time will take additional time** - If your local authority is entering data in Q100 for the first time you will have to build the waste movement tree for the first time. This will take some time and is largely dependent on the complexity of your waste management practices

**Changes to household, commercial and industrial split reporting** – In Q100 you need to report the split for each primary waste management site (e.g. if you send waste to two landfill sites, you need to report splits for each site). This may impact on the way you extract information from your own systems

**Loading “tree structures” from previous quarters** – Once a “tree” is built for one quarter you can reload structures from previous quarters and use them as a basis for your reporting (adjusting tonnages and other details as appropriate). Please see “Loading previous structure” section below for more details.

**Saving changes** - Please use the save button each time you update information in the right-hand waste details section. If you move on to another “branch” of the tree structure without saving in the waste details section you will lose all unsaved work.

**Inputting waste types with different household/commercial splits** - If different types of materials are sent to a single facility but they have a different household/commercial split, you must enter the materials as separate, primary entries in the Waste Movement Tree. **Please consider this point when starting to build your waste movement tree.**

**Amending data** – if amendments to the tree structure are required you have to delete part of all of the previous tree structure and any data then re-build new branch.

## 6.2 How to enter data for the first time in Q100

From the question list select “Q100: waste sent for treatment or disposal”:

- Double-check you have selected the appropriate quarter from the “Enter data for” drop down menu on the top left of the screen. To enter data quarterly, please only enter data in the last

month of the relevant quarter. To enter data annually, only enter data in the last month of the last quarter (i.e. December).

- On the left hand side of the screen under the “Waste Movement Tree”, click on “Q100” (step 1 in *Figure 5* below)

Q100 : This question should be used to record waste sent for treatment or disposal... can be used for all waste streams, but usage differs by country.

+ - All branches With tonnes Imbalances

Go

Q100 1

Waste Details

Facility Type 2 {Select facility type}

Facility Name Select

Waste Stream 3

Save

**Figure 5. To enter waste sent to a treatment facility at the top level of the tree, click on Q100 and enter the details in the *Waste Details* section**

### Facility Type

In the “Waste Details” section, choose the facility type from the drop down list (step 2 in *Figure 5* above). A list of sites where you have previously reported sending waste will appear. The list of sites is determined by the facility type you select and is based on what has been previously reported by your local authority. You may get an error message “There are no facilities of the selected type on your list”. In this case select “Show all my facilities”. This may bring up the site you send the waste to.

### Waste Stream

In the “Waste Details” section, choose the *Waste Stream* type from the drop down list (step 3 in *Figure 5* above).

Table 1 on page 23 provides a summary reference of *Waste Stream*, *Waste Type*, and *Material* to use for inputs and outputs to Q100 *Facility Types*. It is recommended to refer to this table throughout this section.



The waste stream input types available are determined by the Facility Type you select. In some cases there is no choice in the type of waste you can select. For example, any waste sent to a MRF must be defined as co-mingled waste.

The *Waste Stream* input type is only indicative of the waste type that enters a facility. For example, you may send separately collected wood direct to an incinerator. The only input type available for incinerators is “residual waste”. In this case your only option is to enter “residual waste”, but you would still enter the tonnage of “wood” in the more detailed materials section (see “materials” below)

## Facility Name

Also in the “Waste Details” section, click on the “Select” link to choose the facility name (see *Figure 5* above). Once the correct site is available, click on the underlined “Organisation” link to select that site

If the site you are sending waste to is new you will need to add that site to your selection list. Please refer to [section 2 of the WasteDataFlow System Manual](#) on the [WasteDataFlow](#) web site for details on how to add a site to a selection list.

If the site is not available on WasteDataFlow please contact SEPA to have the site added into WasteDataFlow. You will need to provide:

- Company name of facility
- Address of facility including postcode
- Waste licence or waste exemption number
- Principal site activity

To add recycling sites, please use the [Request to add recycling site to the WasteDataFlow list of sites](#) form

## Enter tonnage inputs to sites

After selecting the waste stream input type a tonnage must be entered. For some facility types (e.g. Reprocessor), the option to enter Total Tonnes is not available. This is because the Total Tonnes is automatically calculated from the sum of materials entered in the Materials section.

## Enter Waste source split (household, commercial, industrial)

- Enter the household, commercial, or industrial tonnages that were sent to a waste management facility
- **If different types of materials which are sent to a single facility have a different household/commercial split, you must enter the materials as separate primary entries in the Waste Movement Tree. Please consider this point when starting to build your waste movement tree**
- For example, you send 500 tonnes of wood to Incinerator A that is 100% household-sourced and 200 tonnes of chipboard to Incinerator A that is 50:50 household and commercial-sourced
  - The 500 tonnes of wood should be entered under the Waste Movement Tree as a separate entry with a Waste Source Split of 500:0:0
  - The 200 tonnes of chipboard should be entered under the Waste Movement Tree as a separate entry with a Waste Source Split of 100:100:0
- **The waste source split is only entered for waste sent directly to a facility (primary facility). There is no option to enter waste source split when you are reporting waste that has already been through a previous, primary treatment step. For example you are reporting composting of green waste that was sourced from an MBT plant (which treated residual waste). You would only report the splits when entering input tonnages for the MBT plant**

Further details about how to allocate household, commercial and industrial waste can be found in section 7.5 on page 63.

## Enter Waste Materials

Use this section to report tonnages by material type. Please note that for some processes (e.g. residual waste sent directly to landfill) **you will not have tonnages by material type.**

- Click the Expand tab on the materials section to access a list of materials to enter tonnages against. Once you have entered tonnages, click collapse and save.
- **Please note that all the materials included may not be applicable in Scotland.**

Please refer to the Material column in *Table 1* on page 23 as a guide to *Materials* to use as inputs for various facility types

## Transfer stations

Only use this section if the waste passed through a transfer station on its way to the management site.

- In the Transfer stations tab enter the tonnage against the transfer station
- If a transfer station is not on the selection list refer to [section 2 of the WasteDataFlow System Manual](#) on the [WasteDataFlow](#) web site for details on how to add a transfer station to a selection list

## Comments

- Please use this section to provide any supporting information that you think may be useful
- For waste management processes and/or waste types e.g. Other materials where we need specific comments please refer to the site-specific advice sections further on in the guidance

## Final destinations and commercial confidentiality

Some organisations may be reluctant to provide information about the *Final Destination* of waste due to concerns that competitors may use this knowledge to gain a business advantage. Although reporting the Final Destination in WasteDataFlow is not a new requirement, the Question 100 interface is reliant on accurate *Final Destination* information. An understanding of Final Destinations is key to the Zero Waste Plan target of improving the quality of waste as a resource. SEPA acknowledges the reticence of some businesses to provide *Final Destination* information as a legitimate concern, however it does not regard this as just cause to withhold the provision of this information. Furthermore, it should be noted that:

- Any published statistics will use the information in general terms, such as part of a broader dataset on the general geographical destination of waste. It may also use the information in validating consistency between datasets, for example, licence site returns.
- The Final Destination is not visible to third parties in WasteDataFlow prior to rolling up the data to level 40.
- All waste managers/brokers have a duty of care to know the Final Destination of all waste that it handles. This includes the provision of this information to the Local Authority when they accept its waste
- Third parties will always be consulted before any information is provided under FOI

## 6.3 How to report outputs

For the majority of waste types managed by a facility you need to report what happens to the waste after it leaves that facility using the waste outputs function

For each waste output you should account for that waste until it reaches what is considered a final destination

Final destinations can be landfill sites, compost plants and re-processors

Significant tonnage may also be “lost” from treatment plants such as incinerators, but there are still outputs that need to be reported (e.g. bottom ash, metals, fly ash)

A useful working example of how the waste movement tree is built using outputs for an incineration facility may be found in *Figure 24* on page 50. Each output from the residual MRF primary facility is used to “build” the waste movement tree until all waste outputs are accounted for.

## Waste Type

To report outputs from a waste management facility, use the “New Output” button in “Waste details” and then select *Waste Type* (see *Figure 6* below).

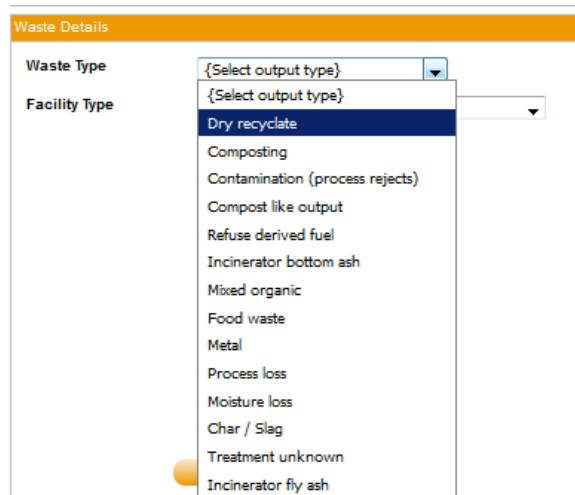

**Figure 6. Waste type list for a new Output. In this instance the waste type list is for an output from Other Method.**

The output *Waste Types* listed are specific by the Facility Type that the new output is from. For example, *Dry Recyclate* is available as an output waste type from a Recycling facility but not from a Composting facility.

Not all output *Waste Types* are relevant for Scotland. Please refer to *Table 1* on page 23 as a reference for the output *Waste Type* that can be used for waste sent from a Facility Type.

Like waste inputs, the output *Waste Type* is only indicative of the type of waste that leaves a facility. For example, an MBT plant might send treated waste for further separation in a dirty MRF. The only relevant output type to select in this case would be “contamination (process rejects)”

## Facility Type

After entering *Waste Type*, select the *Facility Type* to define where the output is sent to (see *Figure 7* below).

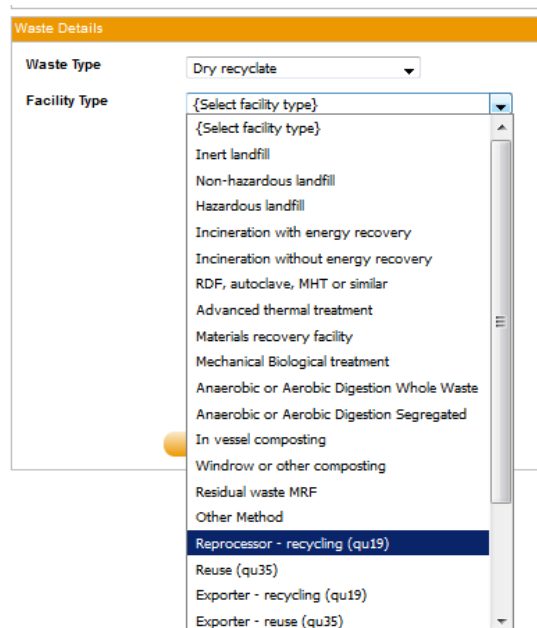

**Figure 7. Facility Type for a new Output.**

For each output reported, you must then go on to report what happens to that output at the next facility, using the same process described above. Continue this process until the waste reaches a final management– a Landfill facility, or a Recycling / Reuse / Composting facility.

- For example, you report contamination (process rejects) as one of the outputs from a clean MRF. You might report the rejects as going to an incinerator, and then report the separate incinerator outputs (e.g. bottom ash, metals recycled or landfilled)

Note: To designate a Recycling or Reuse facility as a final destination for waste, a *Final Destination* facility must be recorded as an output from the facility. Please see the section *Designating a re-processor as a final destination* in section 6.4.3 on page 32 for further details. A *Final Destination* is not required to be added as an output from a Landfill facility – the final destination status is implied.

### Loading previous tree structures

This part of the guidance briefly explains how to reload previous tree structures and make amendments to the structure, with some important caveats

**Please note - if you are new to WasteDataFlow but your authority has previously entered data under Q100 you must still read through this Q100 guidance from start to finish. You must spend time familiarising yourself with how data is entered in Q100 before following the guidance below on reloading previous structures**

To start entering data for a current quarter based on the tree from a previous quarter:

- Use the 'Load from `period`' feature
- Select the previous quarter you wish to load from, this should pull through the tree previously built up for this period

**Please note - loading from previous periods will overwrite anything you have already entered in the current reporting period, so reload the tree and then start to enter data, rather than the other way around**

- After reloading a previous structure you will need to amend the Waste Details, Materials, and Sources / Comments / Transfer Stations by firstly clicking on the appropriate part of the tree branch. This will populate the relevant Waste Details, Materials and Sources / Comments / Transfer Stations under the tree. Use the save and delete tabs to amend waste details.

**Please note: The waste movement tree structure is not particularly flexible. For example, you want to change the type of facility from a MRF to a MBT or residual waste MRF, but some of the outputs destinations (e.g. re-processors or incinerators) stay the same.** Unfortunately, in this example you cannot change the facility from a MRF to another facility type. You have to delete the current MRF *and all the outputs* previously built before rebuilding a new facility with new outputs.

**Table 1. How to report waste inputs and outputs in Q100**

<b>TO facility</b>	<b>FROM facility</b>	<b>Material</b>	<b>Output Waste Type</b>	<b>Waste stream</b>
<b>Landfill</b>	None (primary input)	Residual waste - do not enter material	not applicable	Residual Waste Rejects from collection
	Incineration	Incinerator bottom ash Metals from incinerator bottom ash Other materials (Incinerator fly ash)	Incinerator bottom ash Metal Incinerator fly ash	prefilled
	MRF (Residual) MBT RDF Other method (Residual) Other method (Segregated) Composting / AD Reprocessor, Reuse MRF	Same as input material(s) of FROM facility	Contamination (rejects)	
<b>Incineration</b>	None (primary input)	Residual waste - do not enter material	not applicable (primary input)	Residual Waste Rejects from collection
	RDF	Residual waste - do not enter material	Refuse derived fuel	prefilled
	MRF (Residual) MBT RDF Other method (Residual) Other method (Segregated) Composting / AD Reprocessor, Reuse MRF	Same as input material(s) of FROM facility	Contamination (rejects)	

<b>MRF</b>	None (primary input)	Co-mingled materials or one of mixed categories such as Mixed paper & card, Mixed glass, Mix	not applicable (primary input)	Co-mingled recyclate
	MRF, MRF (Residual) MBT RDF Other method (Residual)	Same as input material(s) of FROM facility	Contamination (rejects)	prefilled
	Composting / AD Reprocessor, Reuse	Actual material sent for Reprocessor / Reuse / Composting / AD	Dry recyclate	
<b>RDF</b>	None (primary input)	Co-mingled materials or one of mixed categories such as Mixed paper & card, Mixed glass, Mix	not applicable (primary input)	Residual Waste Rejects from collection
	MRF, MRF (Residual) MBT RDF Other method (Residual)	Same as input material(s) of FROM facility (If Residual waste stream – do not enter material)	Contamination (rejects)	prefilled
	Composting / AD Reprocessor, Reuse	Actual material sent for Reprocessor / Reuse / Composting / AD	Dry recyclate	
<b>Residual MRF</b>	None (primary input)	Residual waste - do not enter material	not applicable (primary input)	Residual Waste Rejects from collection
	MRF, MRF (Residual) MBT RDF Other method	Same as input material(s) of FROM facility	Contamination (rejects)	prefilled
	Composting / AD Reprocessor, Reuse	Actual material sent for Reprocessor / Reuse / Composting / AD	Dry recyclate	



<b>MBT</b>	None (primary input)	Residual waste - do not enter material	not applicable (primary input)	Residual Waste Rejects from collection
	MRF, MRF (Residual) MBT RDF Other method	Same as input material(s) of FROM facility	Contamination (rejects)	prefilled
	Composting / AD Reprocessor, Reuse	Actual material sent for Reprocessor / Reuse / Composting / AD	Dry recycle	
<b>Compost / AD</b>	None (primary input)	Food waste Garden waste Mixed food and garden waste Wood for composting Other compostable waste	not applicable (primary input)	Food waste Green waste Mixed green and food waste
	MRF MRF (Residual) MBT RDF Other method, Composting / AD	Same as input material(s) of FROM facility	Mixed Organic	prefilled
	MBT	Same as input material(s) of FROM facility	Compost like output	
<b>Reprocessor / reuse</b>	None (primary input)	Any material that can be recycled (except for compostable wastes)	not applicable (primary input)	Source segregated recycle
	MRF MRF (Residual) MBT RDF Other method, Compost / AD	Any material that can be recycled (except for compostable wastes)	Dry recycle	prefilled

<b>Final Destination</b>	Reprocessor / Reuse	not applicable	not applicable	not applicable
	Composting / AD	Same as input material(s) of FROM facility	Composting	
<b>Other Method</b>	Reprocessor / Reuse	not applicable	not applicable	Residual Waste Rejects from collection Source segregated recycle
	MRF MRF (Residual) MBT RDF Other method, Compost / AD	Same as input material(s) of FROM facility	Contamination (rejects)	prefilled
	Composting / AD	Same as input material(s) of FROM facility	Composting	

\*Notes:

- Incineration includes Incineration with energy recovery, Incineration without energy recovery, Advanced thermal treatment
- Landfill include Non-hazardous landfill, Inert landfill, Hazardous landfill
- Final destination includes Final Destination, Final Destination – PAS compliant, Final Destination – Accredited Exporter where relevant.
- Reprocessor / Reuse include Reprocessor – recycling and Exporter – recycling, Reuse – recycling, Exporter - recycling
- Contamination (Rejects) include Contamination (process rejects) and Contamination (gate rejects) include
- Compost / AD include Windrow composting, In-vessel composting, Anaerobic digestion (source segregated)

## 6.4 Site-specific guidance for Q100

See the earlier sections for generic guidance on how to report inputs and outputs in the waste movement tree and waste details sections for each facility type.

### 6.4.1 Residual waste sent to an incinerator



Table 1 on page 23 summarises how to report the inputs to and outputs from facilities in Q100, including incineration facilities. Table 2 below specifically summarises how to report incineration outputs.

An example of residual waste sent for incineration, and the resulting Q100 tree is depicted Figure 8 below.

For reporting IBA in the materials section, please use the “Incinerator Bottom Ash”. If the amount of IBA landfilled is unknown, then use 20% of the waste inputs and assume IBA is landfilled at unknown non-hazardous landfill in Scotland/outwith Scotland.

For both outputs “IBA for recycling” and “metals” designate this waste as recycled at a final destination. IBA is usually 20% of the waste inputs, and metals up to 3% of municipal waste incinerated. To do this, please refer to section 6.4.3 on page 31. If the amount of Metal recycled is unknown, then use 2.5% of waste inputs and assume its recycled at unknown re-processor within Scotland/outwith Scotland (this apply only for municipal waste only). For RDF, Tyres and Wood incinerated, assume zero metal output.

Entering tonnages against process loss is not required. Any imbalance of inputs and outputs will be assumed to be process loss.

**Table 2: How to report incinerator outputs**

Output	Waste Type	Facility Type	Material to report
IBA sent to landfill	Incinerator bottom ash	Appropriate landfill site type	Incinerator bottom ash
IBA sent for recycling	Incinerator bottom ash	Re-processor – recycling	Incinerator bottom ash
Metals sent for recycling	Metal	Re-processor – recycling	Metals from incinerator bottom ash
Incinerator fly ash	Incinerator fly ash	Appropriate landfill site type	Other materials

**Example of how to record waste sent to Incineration:**

The example in Figure 8 below depicts how to record residual waste sent direct from collection to an incineration facility. Please refer to section 6.2 on page 15 for an introduction on who to allocate the waste source split, or for additional detail section 7.5 on page 63.

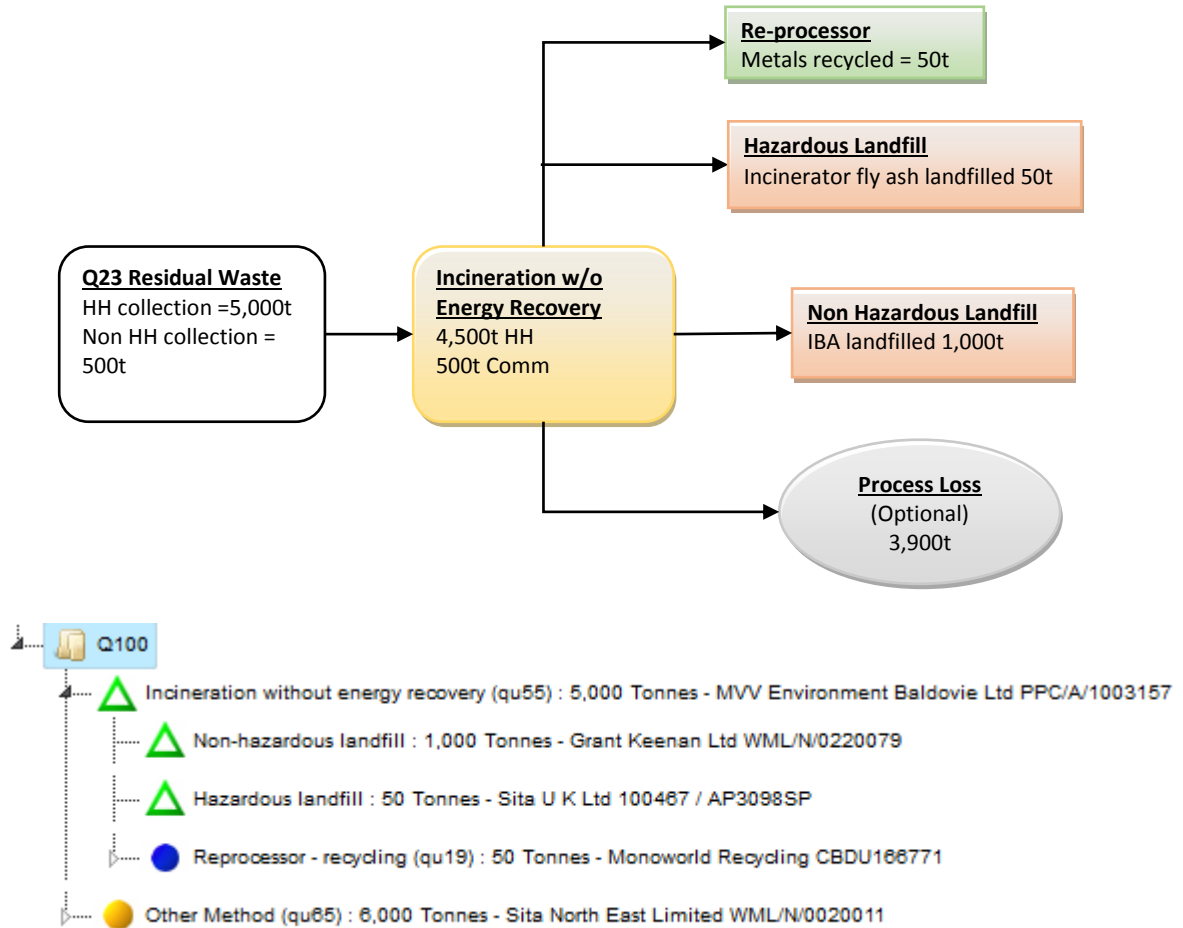

*Note: company names used are for illustrative purposes only and may not be indicative of waste management at that facility.*

**Figure 8. Flow chart depicting waste sent direct to incineration and Q100 tree structure**

## 6.4.2 Residual waste sent to landfill



Table 1 on page 23 includes a summary of how to report the inputs to and outputs from facilities in Q100, including landfill facilities.

An example of residual waste sent to landfill, and the resulting Q100 tree is depicted Figure 9 below.

For landfill sites, once you have entered the waste stream type as Residual waste, tonnes input and waste source splits (and then saved) you do not need to report any outputs/final destinations. This is indicated by a green triangle in the waste movement tree.

**It is not possible to create outputs from a landfill facility**

### Example of how to record waste sent to Landfill:

In this example 10,000 tonnes of residual waste from regular kerbside collections were sent to landfill. The kerbside collections included some commercial properties, with 9,000 tonnes from household collections and 1,000 tonnes from commercial collections.

There were also 600 tonnes of demolition waste arising from a restoration project of an authority building. Of the 600 tonnes, 100 tonnes was asbestos waste.

Figure 9 below depicts how to record the residual waste sent direct from collection to a landfill facility. The 10,000 tonnes is recorded as sent to a non hazardous landfill, with a household / commercial / industrial split of 9,000 / 1,000 / 0 tonnes. For the construction waste, 500 tonnes is recorded as sent to an inert landfill with a household / commercial / industrial split of 0 / 0 / 500 tonnes, and 100 tonnes (the asbestos) is recorded as sent to hazardous landfill with a household / commercial / industrial split of 0 / 0 / 100 tonnes.

As this is residual waste the collection should be recorded in Q23. For the kerbside collections, 9,000 tonnes is recorded as *Collected household waste: Regular Collection* and 1,000 tonnes as *Collected non-household waste: Commercial & Industrial*. For the construction waste, 500 tonnes is recorded as *Collected non-household waste: Construction and Demolition* and 100 tonnes as *Asbestos Waste separately collected*. Please refer to section 7.5 on page 63 for additional details about the allocation of household, commercial and industrial waste for Q23.

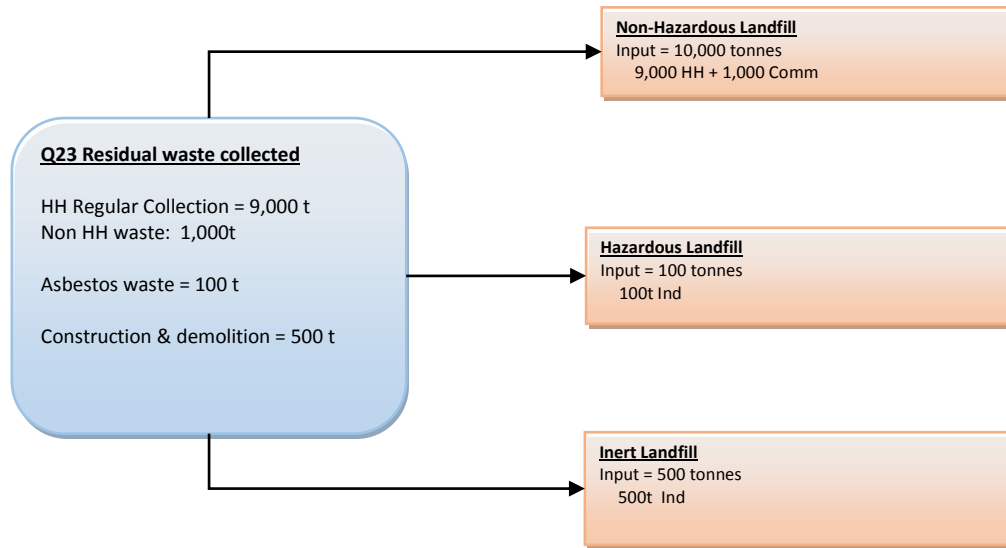

☐ Q100:Waste sent for treatment or disposal

- △ Inert landfill (qu51) : 500 Tonnes : Residual waste : Marshall Farms (Alloa)  
WML/E/0020171
- △ Non-hazardous landfill (qu52) : 4,000 Tonnes : Residual waste : G R Service  
Company PPC/A/1004300
- △ Non-hazardous landfill (qu52) : 6,000 Tonnes : Residual waste : Shanks  
Avondale Ltd PPC/E/0020059
- △ Hazardous landfill (qu53) : 100 Tonnes : Residual waste : Shanks Avondale Ltd  
PPC/E/0020059

*Note: company names used are for illustrative purposes only and may not be indicative of waste management at that facility.*

**Figure 9. Flow chart depicting waste sent direct to landfill and Q100 tree structure**

### 6.4.3 Recyclables sent to a re-processor

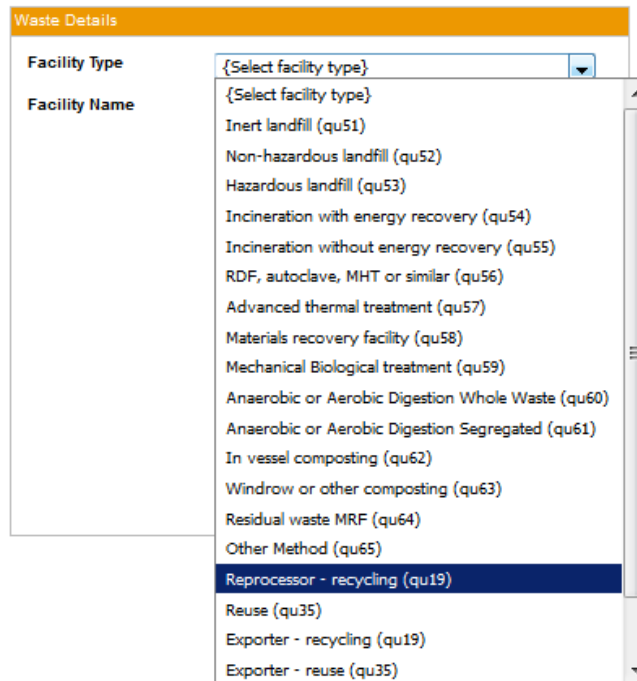

Table 1 on page 23 includes a summary of how to report the inputs to and outputs from facilities in Q100, including Recycling and Reuse facilities. Table 3 below specifically summarises how to report recycling / reuse outputs.

An example of source segregated waste sent for recycling, and the resulting Q100 tree is depicted in Figure 10 below.

A re-processor is defined as a facility that transforms waste into a product that is not a waste. Transfer stations, waste carriers, waste brokers, and MRFs should not be designated as a re-processor. Reuse is where waste is checked or cleaned to use again as a product for which the material was originally used.

The *Facility Type* to be used for re-processors when inputting waste details in question 100 should be: *Re-processor – recycling*, *Reuse*, *Exporter – recycling*, and *Exporter – reuse* (see Figure 10 below). Organics sent to composting should **not** be entered as going to a re-processor (for composting see section 6.4.6 on page 42)



**Figure 10. To record waste recycled or reused, in the Waste Details section choose one of the Recycling or Reuse facility types**

For common recyclate (e.g. glass, plastic, paper, card) sent directly to a re-processor choose *Source Segregated Recyclate* from the *Waste Stream* drop down box (see Figure 11 below).

The image shows a software interface titled "Waste Details". It contains three fields:

- Facility Type:** A dropdown menu with the selected option "Reprocessor - recycling (qu19)".
- Facility Name:** A text field with the placeholder text "Select".
- Waste Stream:** A dropdown menu with the selected option "Source segregated recyclate". The menu is open, showing other options: "Food waste", "Green waste", and "Mixed green and food waste".

**Figure 11. For recycling and reuse facility types, choose Source segregated recyclate as the Waste Stream.**

We do not normally expect more than one material type to go the same recycling facility e.g. glass and metal. Please enter the data for different material types going to a reprocessor as separate entries in Q100.

**Do not add another re-processor as an output from a re-processor.**

#### Reporting re-processor rejects

Waste rejected by a re-processor should be reported as an output (*Contamination (gate rejects)*) from the site.

Enter reject tonnages using the same material category as recorded for inputs. For example, if the rejects were from green glass inputs enter the rejects as green glass.

#### Designating a re-processor as a final destination

A re-processor is designated as a final destination in Q100 when there is a final destination output.

Click on the re-processor in the *Waste Movement* tree. In the *Waste Details* click on the *Auto FD* button. Choose *Dry Recyclate* as the *Waste Type* and *Final Destination* as the *Facility Type*, click save. There is no requirement to enter tonnages for the Final Destination.



**Waste Details**

Facility Type: Reprocessor - recycling (qu19)  
 Facility Name: Clean Tech Europe Limited [Select](#)  
 Facility Description:   
 Facility Address: Hemswell Business Park, Hemswell, Lincolnshire  
 Facility Postcode: DN21 5TU  
 Facility Licence: EB3704KZ  
 National Facility ID: 40797  
 Waste Stream: No Waste Stream Type  
 Tonnes (By Material): 500

Buttons: Save, New Output, **Auto FD**, Delete

↓

**Waste Details**

Waste Type: Dry recycle  
 Facility Type: Final Destination

Buttons: Save, Cancel

**Figure 12. Use the Auto FD facility to mark the recycling or reuse facility as an end destination.**

Do not use the comments box for facility name and number in the final destination. This is the same as the re-processor you have already reported

**Table 3: How to report reuse and reprocessor outputs**

Output	Waste Type	Facility Type	Material to report
Waste recycled by reprocessor into a product	Dry Recyclate	Final Destination	Material and tonnes is not required
Reprocessor rejects	Contamination (Process Rejects) Contamination (Gate Rejects)	Landfill Incinerator MRF Residual MRF	Same as input material

**Example of how to record waste sent to reprocessor:**

In this example source segregated mixed glass (1,000 tonnes), mixed plastic bottles (500 tonnes) and paper (500 tonnes) were sent to a reprocessor. The mixed glass was collected from 90% household sources and 10% from commercial sources. The plastic and paper were 100% from household sources. All these wastes were collected from kerbside collections. For the paper waste, there were 5% rejects at the reprocessor.

As these are kerbside collected waste record the collection of household tonnages in Q10. In Q100 enter each waste stream as a separate branch as described above. For the paper enter an output to landfill using Waste Type of *Contamination (Process rejects)* and material as *Paper*.

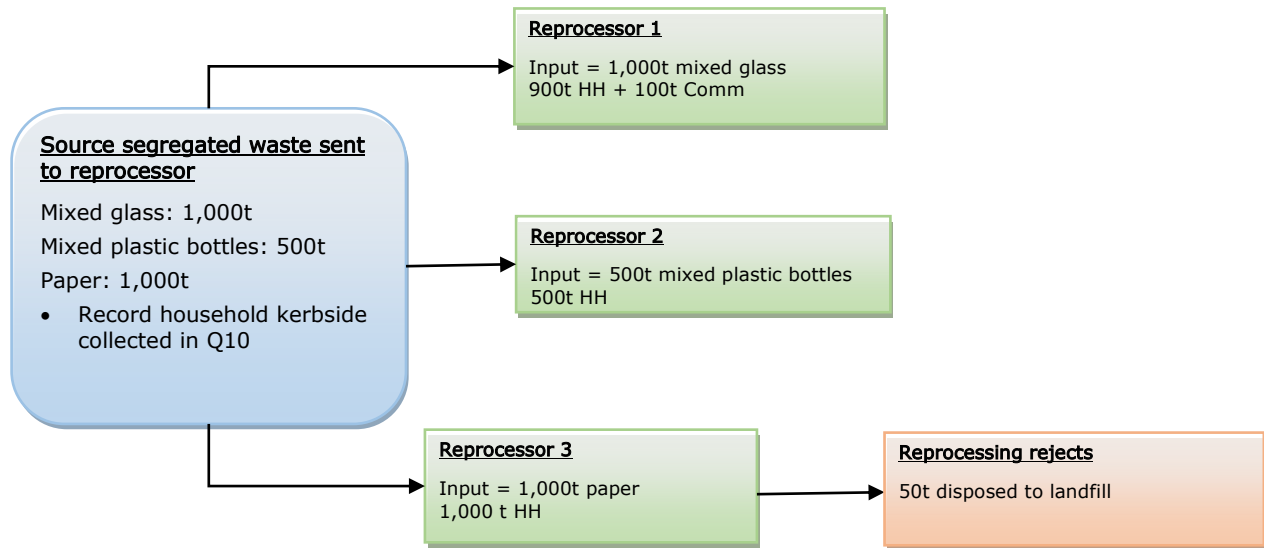

Note: company names used are for illustrative purposes only and may not be indicative of waste management at that facility.

**Figure 13. Flow chart depicting waste sent direct to reprocessor and Q100 tree structure**

#### 6.4.4 Recyclables sent to a clean Materials Recovery Facility (MRF)



Table 1 on page 23 summarises how to report the inputs to and outputs from facilities in Q100, including clean MRF facilities. Table 4 below specifically summarises how to report MRF Outputs.

An example of residual waste sent to a clean MRF, and the resulting Q100 tree is depicted Figure 16 below. The *Facility Type* to be used for re-processors when inputting waste details in Q100 should be *Materials recovery facility* (see Figure 14 below).

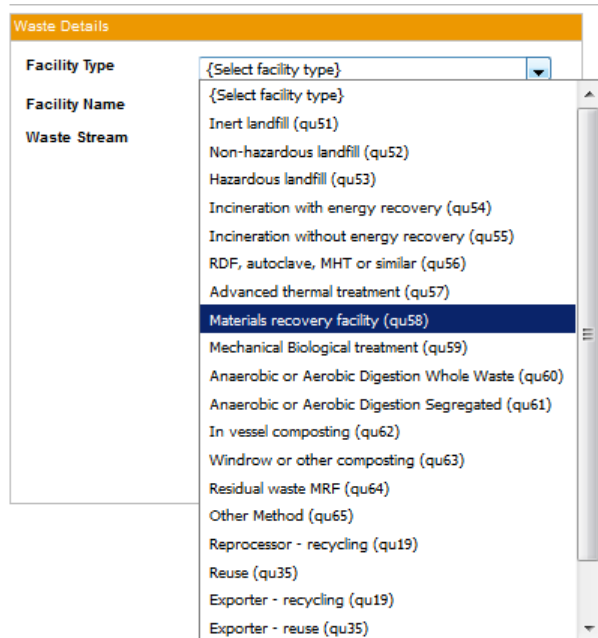

**Figure 14. To record source segregated mixed materials sent to a MRF for separation, in the Waste Details section choose Materials recovery facility.**

*Comingled recyclate* is the only option for the *Waste Stream* and is selected by default (see Figure 16 below)

The screenshot shows a web form titled 'Waste Details'. It contains three fields: 'Facility Type' with a dropdown menu set to 'Materials recovery facility (qu58)', 'Facility Name' with a 'Select' link, and 'Waste Stream' with a dropdown menu set to 'Comingled recyclate'. The 'Waste Stream' dropdown is open, showing 'Comingled recyclate' as the selected option.

**Figure 15. For MRF facility use the default Waste Stream of Comingled recyclate.**

Where source segregated recyclate is also sent to the same MRF, but does not enter the treatment process (e.g. is used to bulk up sorted waste), do not record the source segregated material as a MRF input. In this instance the MRF is effectively a transfer station so should not be recorded in the Q100 tree. Waste should only be recorded in the Q100 tree when it is sent for treatment.

No weight loss is expected from treatment of waste at a clean MRF, therefore, if any weight loss occurs, please provide the reason behind it in comments section.

Clean MRFs rejects are usually within a range of 5% - 40%. Evidence for rejects outwith the acceptable range should be provided to SEPA Waste Data staff.

### How to report MRF outputs

Outputs to re-processors (e.g. glass, paper, card, plastic) should be reported following the guidance in section on page 31.

The re-processor must be the facility where the material is converted into a final product. It cannot be a transfer station or the MRF itself. The MRF operator will be able to provide you with these details. If final destination is unknown, the next known destination should be reported. In exceptional circumstances, where after making a reasonable effort the final destination cannot be found, report it as “unknown” (see section 6.5 on page 61 for more details).

*Note: If actual final destinations are not recorded, this will likely impact on the quality assessment of your authority data in SEPA statistical publications.*

**Table 4: How to report clean MRF outputs**

Output	Waste Type	Facility type	Material to report
Recyclables sent for remanufacture	Dry recyclate	Re-processor – recycling, Export – recycling	Actual recyclables
Rejects disposal	Contamination (Process rejects)	One of the Landfill or Incineration methods	Same material as inputs
Partially treated recyclate sent to another treatment facility	Contamination (Process rejects)	Any management method (e.g. another MRF, MBT, Other treatment)	Same material as inputs

### Example of how to record waste sent to a MRF:

In this example source segregated mixed co-mingled material (5,000 tonnes) were sent to a MRF. The materials was collected from 90% household sources and 10% from commercial sources. All these wastes were collected from kerbside collections. There were 10% rejects from this MRF which were landfilled.

As these are kerbside collected waste record the collection of household tonnages in Q10.

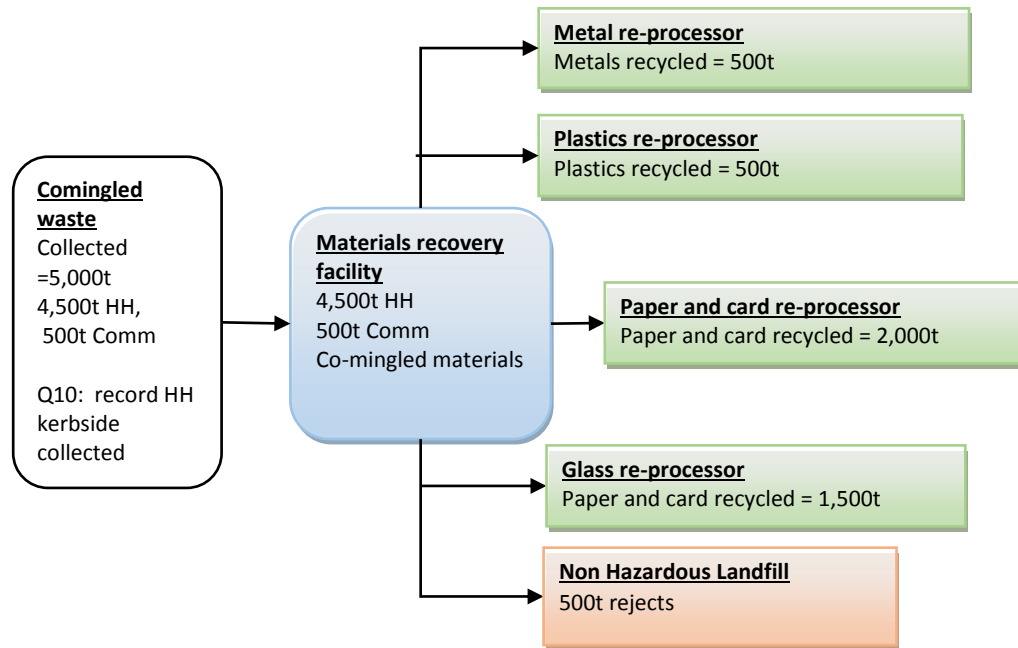

*Note: company names used are for illustrative purposes only and may not be indicative of waste management at that facility.*

**Figure 16. Flow chart depicting waste sent to clean MRF and Q100 tree structure**

## 6.4.5 Recyclables sent to other treatment method

Use the *Other Method* when the waste treatment does not easily fall into any of the other Facility Types.

Please refer to Table 1 on page 23 includes a summary of how to report the inputs to and outputs from facilities in Q100, including *Other Method* facility type.

The *Other Method* facility type is unique in that it can take either Residual Waste or Source Segregated Recyclate as a Waste Stream Type (see Figure below)

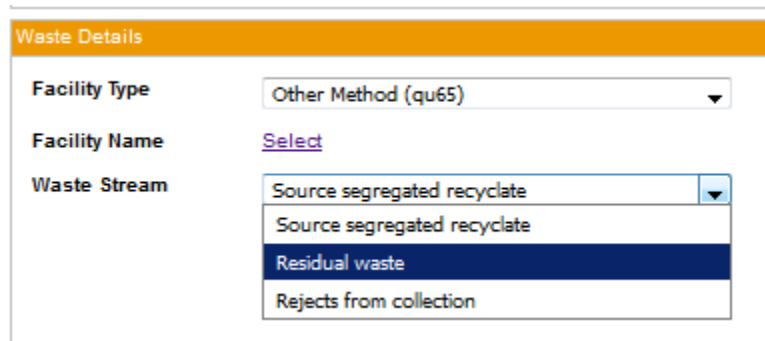

The screenshot shows a form titled "Waste Details" with an orange header. It contains three fields: "Facility Type" with a dropdown menu showing "Other Method (qu65)", "Facility Name" with a "Select" link, and "Waste Stream" with a dropdown menu. The dropdown menu for "Waste Stream" is open, showing four options: "Source segregated recyclate", "Source segregated recyclate", "Residual waste" (which is highlighted in blue), and "Rejects from collection".

**Figure 17. Other Method can uniquely take either *Residual Waste* or *Source segregated recyclate* for Waste Stream.**

### Residual Waste Stream

Use Residual Waste stream where the waste has been collected as part of the residual waste infrastructure. The collection of the waste should also be recorded in Q23.

### Source Segregated Waste Stream

Use the Source Segregated waste stream where the collection of the waste is part of your local authority source segregated collection – for example it was collected in kerbside, at Bring banks, or via separate collections at civic amenity sites. For kerbside collected waste of household origin, the collection should also be recorded in Q10.

The Other Method facility should be used for physical treatment of waste, with waste outputs sent to a re-processor. Appropriate uses of the *Other Method* (Source segregated recyclate) include:

- Physical treatment of WEEE, Textiles & footwear prior to outputs being sent to a re-processor
- Physical treatment of wood to remove metal prior to sending wood for recycling and metal for recycling
- Any other facility where the source segregated recyclate is physically treated to produce two or more components before being sent to a re-processor

The Other Method facility (Residual Waste) should be used to record Street Sweeping.

### Example of how to record waste using Other Method – Street Sweeping:

This is an example of a waste that is recorded using the *Residual Waste* Stream Type. The collection is also recorded in Q23 *Collected household waste : Street Cleaning*. As indicated in Table 8 on page 64, this waste is considered Commercial waste and does **not** count toward household waste targets. Therefore in Q100 record the Source Split to Other Method as 100% commercial.

For the biodegradable component, record the waste as per waste sent to Compost in section 6.4.6 below. The *Waste Type* should be recorded as *Mixed Organic*. In the materials, section select 'Other compostable waste' and assign the quantity against it.

Assign the compost amount to 'Final Destination'. We do not expect this waste would PAS compliant.

For the non-biodegradable part, record the waste as sent to a reprocessor (for details of waste sent to reprocessor see section 6.4.3 above). Record the *Waste Type* as *Source segregated recyclate* and the Material is 'Aggregate'. Assign the Dry recyclate material to the final destination.

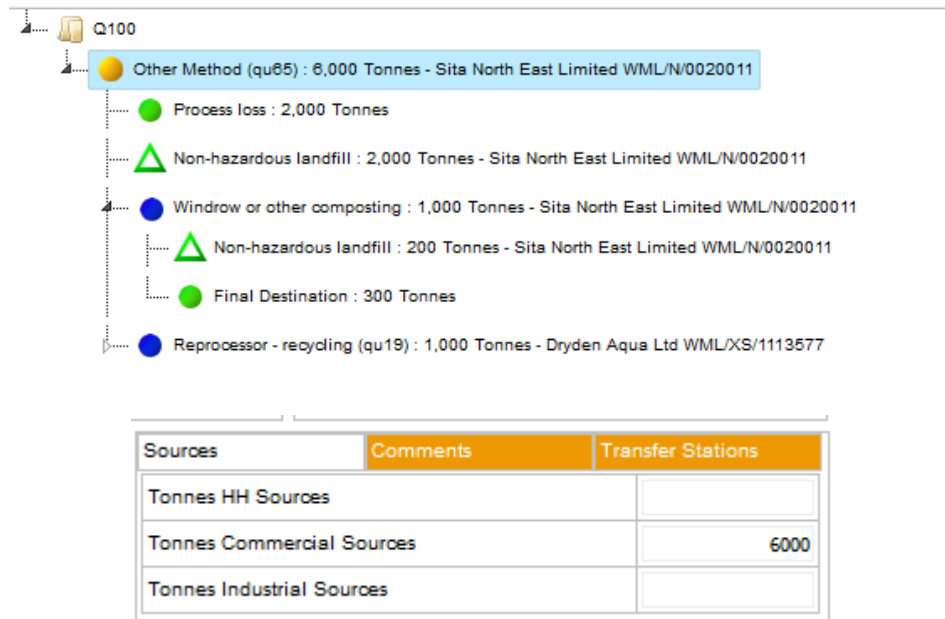
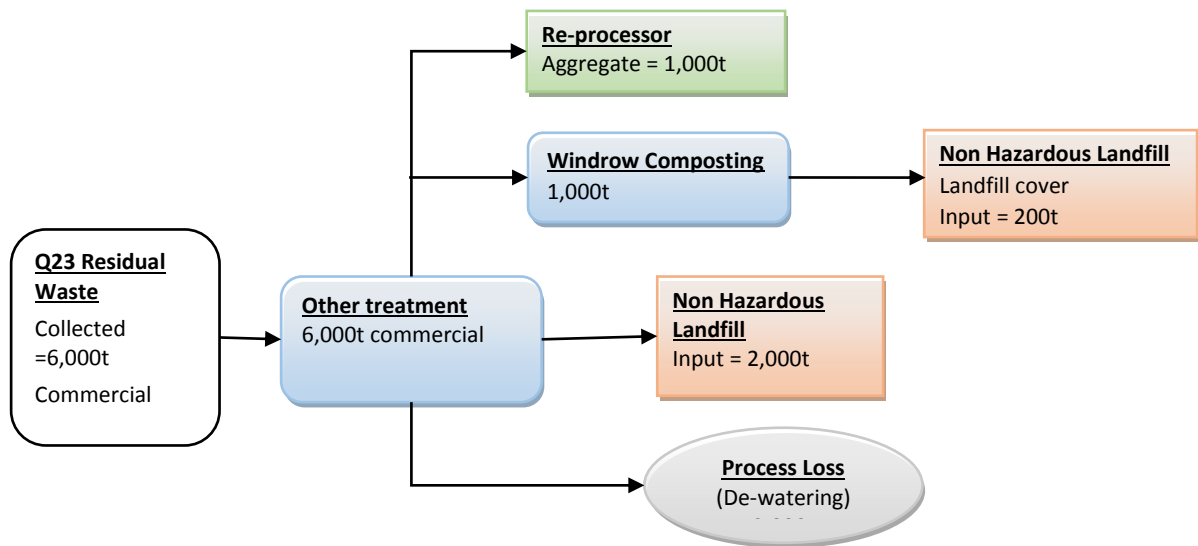

Note: company names used are for illustrative purposes only and may not be indicative of waste management at that facility.

**Figure 18. Flow chart showing Street Sweepings sent for treatment and Q100 tree structure**

### Example of how to record waste using Other Method – Treatment of WEEE

This is an example of a *Source Segregated* waste input to Other Method. The Source Segregated WEEE is recorded as input to Other Method. The WEEE is physically treated to produce individual components such as plastics, glass and metal. As depicted in Figure 18 above, these are then recorded as outputs from the Other Method to recycling and / or disposal facilities.



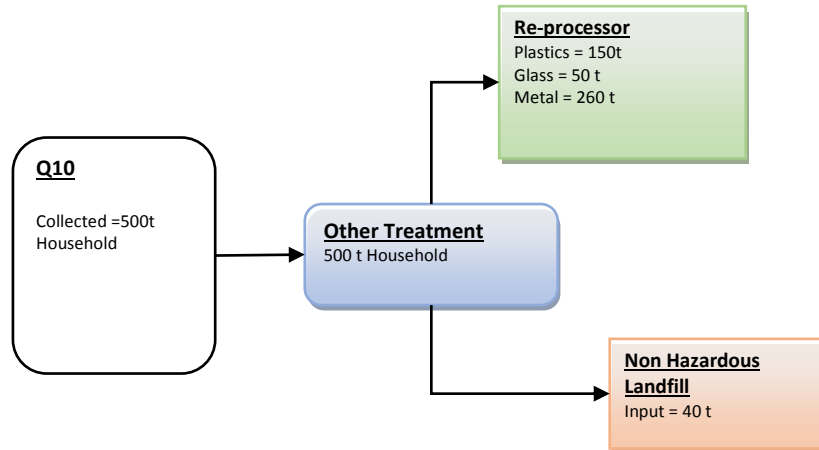

*Note: company names used are for illustrative purposes only and may not be indicative of waste management at that facility.*

**Figure 19. Flow chart showing WEEE sent for treatment and Q100 tree structure**

## 6.4.6 Organic recyclables sent to a Composting Facility



In this section, *composting* refers to composting by windrow and in-vessel composting as well as anaerobic digestion of segregated waste.

Table 1 on page 23 summarises how to report the inputs to and outputs from facilities in Q100, including composting facilities. Table 4 above specifically summarises how to report composting outputs.

A working example of organic recyclables sent for composting, and the resulting Q100 tree is depicted in Figure 21 below.

### Composting Process Rejects

Use *Contamination (process rejects)* as the *Waste Type*

Report tonnages in the materials section using the same material as inputted to the composting site. For example, if *Green Waste* was entered as the waste stream input and there are 50 tonnes of rejects, enter 50 tonnes against the *Green Waste* in the material summary

### Compost Process Weight Loss

It is not required to enter process weight loss. The weight loss is automatically calculated from the difference between the inputs to and outputs from the composting site

It is normally expected there will be between 30% and 60% weight loss during the composting process

Tip - The process weight loss can be determined by clicking on the composting site in the tree and looking at the “Waste Summary” section to the right of the “Waste Movement Tree”. The imbalance in tonnages will be equal to the process weight loss

If the weight loss is not known, assume a weight loss of 50% and note that this is an estimate in the comments box

Please note: process loss does not impact on recycling/composting rates

### PAS100 compliant facilities

PAS100 and PAS110 compliant facilities only, will contribute to recycling rates. Non-compliant management will contribute to “Other recovery”.

To record a composting facility as PAS compliant, enter output tonnes of compost from the PAS compliant process to a Facility Types of **Final Destination – PAS Compliant**.

Do not assume that the PAS compliance status of a composting site is the same as the previous year, as the PAS certification can be removed for sites.

Note: PAS specification states that only source segregated waste should be used as inputs to PAS processes therefore residual waste entering a facility should not be marked as PAS compliant. Where organics from residual waste are recorded as processed via a PAS process, obtain evidence from the operator that this waste went through a PAS process and record this in the comments.

The image shows a screenshot of a software interface titled "Waste Details". It contains several fields: "Output Waste Type" (set to "Composting"), "Facility/Process Type" (set to "{Select Facility Type}"), "Facility Name" (set to "{Select Facility Type}"), and "Tonnes Output". A dropdown menu is open for "Final Destination", listing various options. The option "Final Destination - PAS Compliant" is highlighted in blue and circled in red. Other options include "Final Destination", "Final Destination - Accredited Exporter", "Inert landfill", "Non-hazardous landfill", "Hazardous landfill", "Incineration with energy recovery", "Incineration without energy recovery", "RDF, autoclave, MHT or similar", "Advanced thermal treatment", "Materials recovery facility", "Mechanical Biological treatment", "Anaerobic or Aerobic Digestion Whole Waste", "Anaerobic or Aerobic Digestion Segregated", "In vessel composting", "Windrow or other composting", "Residual waste MRF", "Other Method", "Reprocessor - recycling (qu19)", "Reuse (qu35)", "Exporter - recycling (qu19)", "Exporter - reuse (qu35)", "Resource recovery park", and "Interim storage".

**Figure 20. Choose the “Final Destination – PAS Compliant” to record PAS compliant compost outputs**

### Non-PAS100 compliant composting sites

For non-PAS100 facilities only, enter the licence number or waste exemption number *of the premises where the compost was used* in the comments box (e.g. the licence number which allows the use of the waste as a soil conditioner, landscaping or landfill restoration)

For PAS-100 facilities, the compost is no longer considered a waste – the reuse of material is not required to go to a licensed or exempt site

To record the composting management as non PAS compliant, enter tonnages into a *Final Destination* output instead of a *Final Destination – PAS Compliant* output.

### Stockpiled compost

- Select *Composting* as the output waste type and *Interim Storage* as the *Facility Type*. Click save and enter the tonnages stockpiled in the Materials section. To report by material use the same materials as reported for inputs

## Example of how to record waste sent for composting

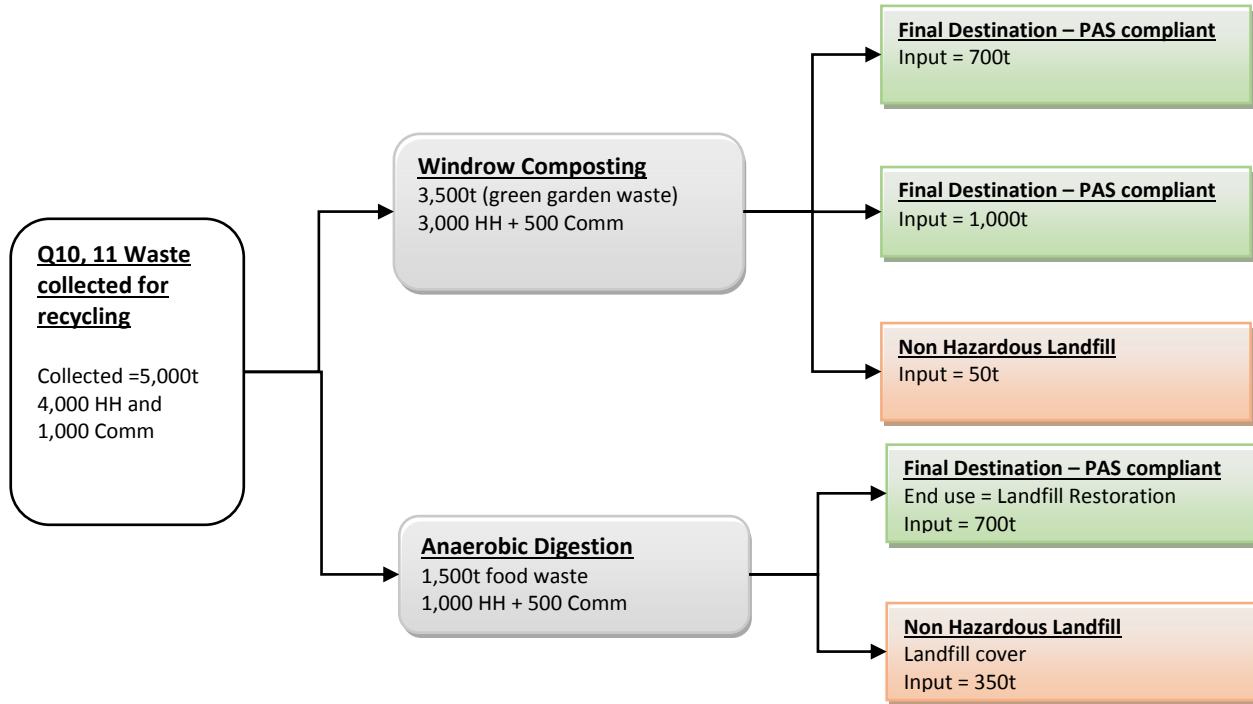

### Q100: Waste sent for treatment or disposal

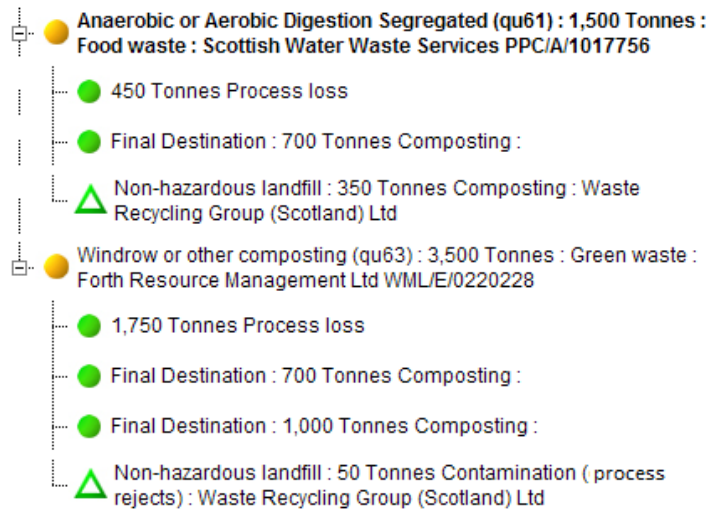

Note: company names used are for illustrative purposes only and may not be indicative of waste management at that facility.

**Figure 21. Flow chart showing waste sent for composting and Q100 tree structure**

**6.4.7 Residual waste sent direct to Mechanical Biological Treatment (MBT), autoclave, Mechanical Heat Treatment (MHT) plant etc.**



Table 1 on page 23 summarises how to report the inputs to and outputs from facilities in Q100, including incineration facilities. Table 5 below specifically summarises how to report MBT outputs.

A working example of residual waste sent to an MBT facility, and the resulting Q100 tree is depicted in Figure 24 below.

To enter MBT process loss please follow the guidance for *Compost Process Weight Loss* on page 42.

For Compost like output sent for recycling, please enter the facility name into the *Final Destination*. Enter details of the end usage (e.g. “landfill cover”) into the comments section of the *Final Destination*.

**Table 5. How to report MBT outputs**

<b>Output</b>	<b>Output waste type</b>	<b>Facility Type</b>	<b>Material to report</b>
Recyclables sent for remanufacture	Dry recycle	Re-processor – recycling, Export – recycling	Actual recyclables
Rejects sent for disposal	Contamination (Process rejects)	Landfill or Incineration	Actual recyclables if known or Other material
Partially treated waste sent to another facility for further treatment	Contamination (Process rejects)	Other management method (e.g. MRF)	Actual recyclables if known or Other material
Organics sent to composting	Compost like output (CLO)	In-vessel or windrow composting, anaerobic digestion	Actual organics if known or Other compostable waste
Compost like output reused	Compost like output (CLO)	Final destination	Other compostable waste
Compost like output disposed	Compost like output (CLO)	Landfill or Incineration	Other compostable waste

## Example of residual waste sent to an MBT facility

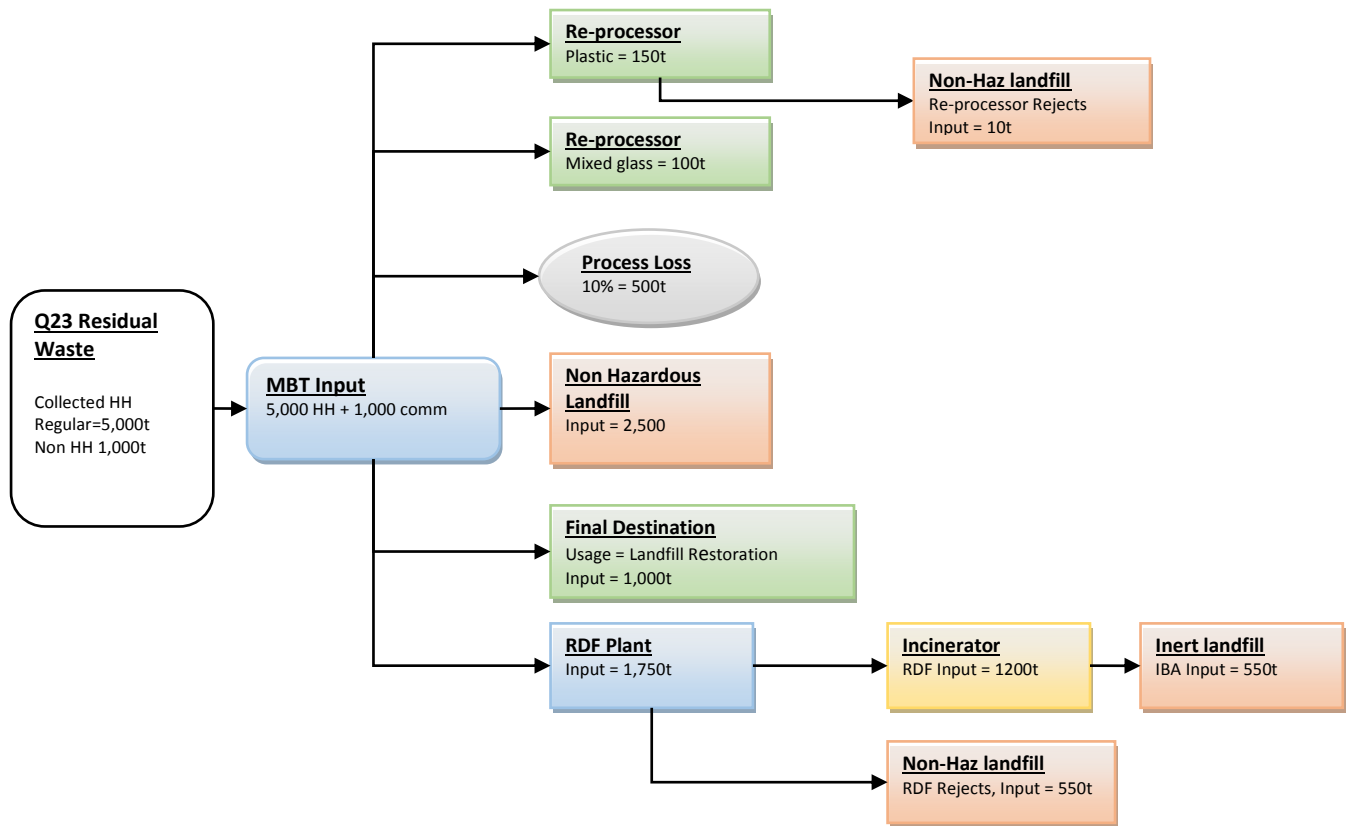

Q100: Waste sent for treatment or disposal

- Mechanical Biological treatment (qu59) : 6,000 Tonnes : Residual waste : Shanks Argyll & Bute Limited PPC/A/1004280
  - 500 Tonnes Process loss
  - Reprocessor - recycling (qu19) : 150 Tonnes Dry recyclate : Viridor Electrical Recycling
  - Reprocessor - recycling (qu19) : 100 Tonnes Dry recyclate : John R Adam & Sons Ltd
  - ▲ Non-hazardous landfill : 2,500 Tonnes Contamination (process rejects) : Shanks Argyll & Bute Limited
  - RDF, autoclave, MHT or similar : 1,750 Tonnes Contamination (process rejects) : P X Ltd
    - ▲ Non-hazardous landfill : 550 Tonnes Contamination (process rejects) : Barr Limited
    - Incineration with energy recovery : 1,200 Tonnes Refuse derived fuel : E.on Stevens Croft Biomass Power Station
    - Final Destination : 1,000 Tonnes Compost like output :

Note: company names used are for illustrative purposes only and may not be indicative of waste management at that facility.

Figure 22. Flow chart showing waste sent to MBT and Q100 tree structure

## MHT and Autoclave outputs

- Use the general guidance for MBT output, except for organic outputs report as in *Table 6* below.
- Where organic outputs are sent direct to a final end use (e.g. landfill restoration) follow the guidance for compost end use in section 6.4.6 on page 42. Enter a description of the usage into the comments box including the name and waste management licence number of the premises where the material was used

**Table 6. How to report organic outputs from RDF/autoclave**

<b>Output</b>	<b>Output waste type</b>	<b>Facility type</b>	<b>Material to report</b>
Organic material sent to further biological treatment MBT or Autoclave	Dry Recyclate or Mixed organic	In-vessel or windrow composting, anaerobic digestion	Other compostable waste
Organic material sent for reuse	Dry Recyclate or Mixed organic	Final destination	Other compostable waste

## 6.4.8 Residual waste sent to Refused Derived Fuel plant (RDF plant)



Table 1 on page 23 includes a summary of how to report the inputs to and outputs from facilities in Q100, including RDF facilities.

An RDF facility is conceptually similar to waste sent to a residual MRF facility, except the purpose of the RDF facility is to produce high calorific waste which can subsequently be sent for incineration.

An example of residual waste sent to an RDF plant to separate high calorific waste is depicted in Figure 23 below.

RDF outputs should always include waste that is sent to an incinerator. Please refer to section 6.4.1 *Residual waste sent to an incinerator* on page 27, on how to enter inputs and outputs to an incineration facility.

There is also usually rejects at the RDF plant stage.

### Example of how to record waste sent to RDF plant

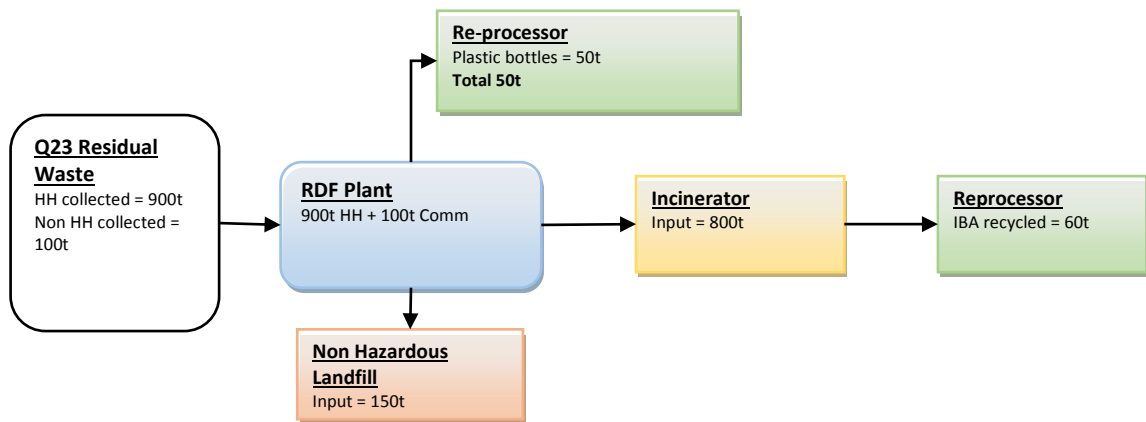

Note: company names used are for illustrative purposes only and may not be indicative of waste management at that facility.

**Figure 23. Depiction of residual waste sent to an RDF plant for sorting high calorific waste prior to incineration**



#### 6.4.9 Waste sent to a residual waste materials recovery facility (dirty MRF)



Table 1 on page 23 includes a summary of how to report the inputs to and outputs from facilities in Q100, including Residual waste MRF facilities.

An example of residual waste sent to a residual waste MRF waste is depicted in Figure 24 below.

No weight loss is expected from treatment of waste at a dirty MRF, therefore, if any weight loss occurs, please provide the reason behind it in comments.

#### Residual waste MRF outputs

For recyclable outputs choose Dry Recyclate as the Output Waste Type and follow the instructions as described in section 6.4.3 on page 31.

For process rejects incinerated or sent to landfill please see the earlier, corresponding site-specific guidance for these site types

## Example of how to record waste sent to residual waste MRF

The example in Figure 24 below depicts how to record residual waste sent direct from collection to a residual waste MRF facility. Please refer to section 6.2 on page 15 for an introduction on how to allocate the waste source split –additional details can also be found in section 7.5 on page 63. As this is residual waste, the collection should also be recorded in Q23.

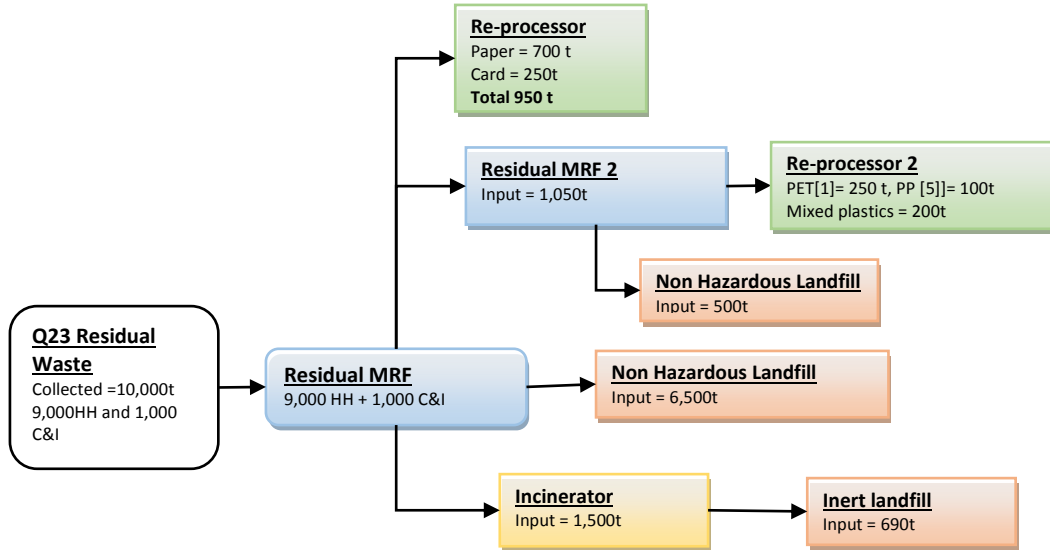

### Q100: Waste sent for treatment or disposal

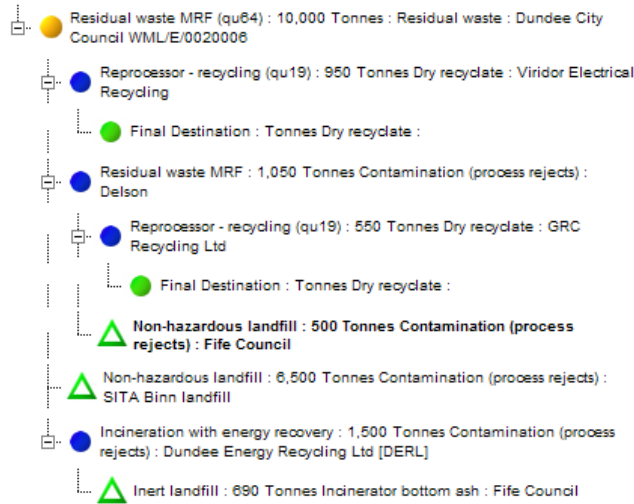

Note: company names used are for illustrative purposes only and may not be indicative of waste management at that facility.

**Figure 24. A depiction of residual waste sent to a dirty MRF and Q100 tree structure.**

## 6.4.10 How to report stockpiling

### Waste outputs sent TO interim storage (Stockpiling)

- Q100 has the management category for the recording of stockpiled compost prior to reuse. It also allows for recording of stockpiled recyclate, such as the output from a MRF.
- Only report stockpiling of material if it is anticipated material will be stored long term (> 6 months) for reasons such as waiting for market conditions to improve for the demand of a material
- **Only report interim storage for waste outputs from a facility**
- For interim storage of stockpiled compost, also refer to the *Stockpiled compost* section on page 43.

Table 7 below summarises how to report outputs to interim storage

**Table 7. How to report waste sent to Interim Storage**

Output	Output waste type	Facility type	Material to report
Dry recyclables stored awaiting remanufacture or disposal	Dry Recyclate	Interim Storage	Actual recyclables
Compost stored awaiting reuse or disposal	Composting	Interim Storage	Input material or Other compostable waste
Compost like output stored awaiting reuse or disposal	Compost like output	Interim Storage	n/a
Refuse derived fuel	Refuse derived fuel	Interim Storage	n/a

### How to Record Waste recycled or disposed FROM Interim Storage

Q100 has the management category for the recording of stockpiled material which has been recorded as stockpiled in a previous quarter.

To record material sent from storage, you will need to assign a facility to the “Stockpile Use”. Please use the “pseudo” facility that has been created for this purpose, **facility number 35070 “Sent from storage”**

*Note: if you cannot find this facility in your selection list you will need to update your selection lists. Please refer to [section 2 of the WasteDataFlow System Manual](#) on the [WasteDataFlow](#) web site for details on how to add a site to a selection list.*

*Please note that for composting and Composting like output, Question 100 expects stockpiled material to originate from the facility where it was originally produced.*

Please see the earlier sections for generic guidance on how to report inputs and outputs in the waste movement tree and waste details sections

- Under the *Waste Movement Tree*, click on the “Q100: Waste sent for treatment or disposal” at the top of the tree
- For *Facility Type* select “*Stockpile Use*”.
- In the *Waste Details* section, for *Waste Stream Type* choose either;
  - For recyclate, choose *Stockpiled Recyclate*
  - For compost, choose *Stockpiled Compost*;
  - For compost like output, choose *Stockpiled CLO*
  - For refuse derived fuel, choose *Stockpiled RDF*
  - For “Facility name” choose facility number 35070 “Sent from storage”

The output from the “Stockpile Use” is dependent on the type of stockpiled material. Please refer to the stockpiling sections and Table 6 below.

When reading the section below, please refer to the example in Figure 25 *below*.

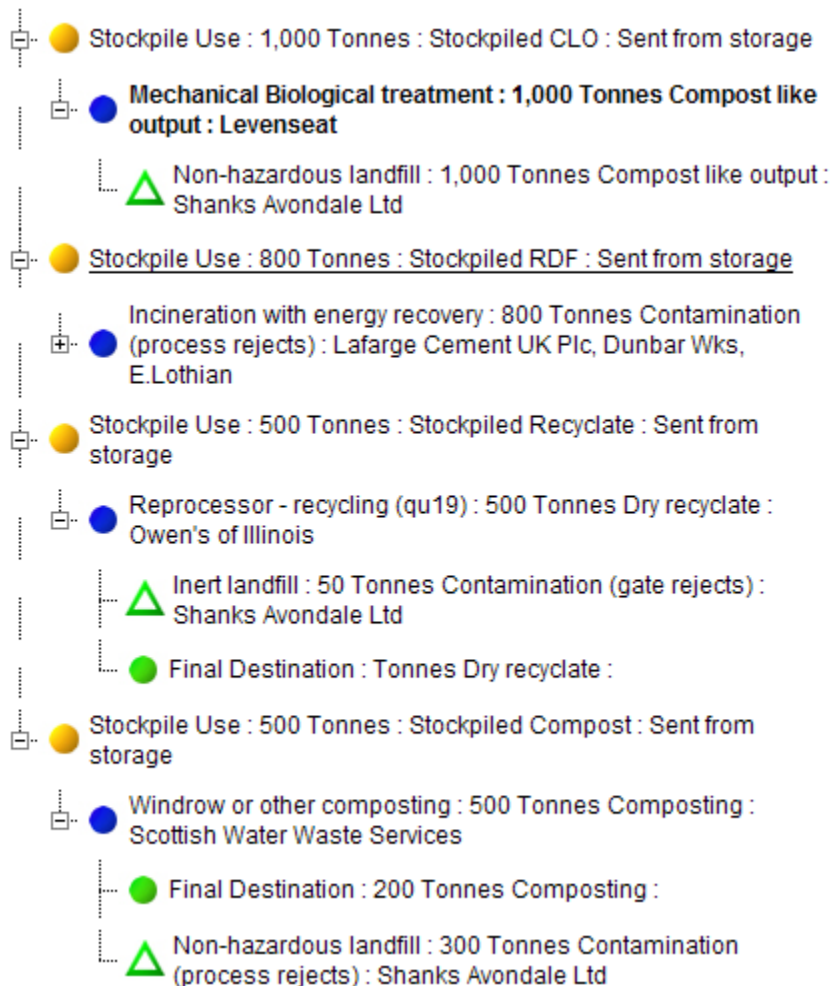

*Note: company names used are for illustrative purposes only and may not be indicative of waste management at that facility.*

**Figure 25. Example question 100 tree for use of stockpiled material**

### Stockpiled Recyclate: Outputs sent to a re-processor

In the Waste Details section, click on “New Output”. Select the Output Waste Type as Dry Recyclate. Select a *Facility Type* of either:

- Re-processor – recycling or;
- Export – recycling

Follow the instructions in *Recyclables sent to a re-processor* section on page 31.

### Stockpiled Compost: Outputs sent for recycling

- In the Waste Details section, click on “New Output”.
- Select the Output Waste Type as Composting.
- Select a *Facility Type* of either:
  - Anaerobic or Aerobic Digestion Segregated
  - In-vessel composting; or
  - Windrow or other composting.

For the Composting Facility Name, **use the facility name of the composting site which the stockpiled material was originally output.**

For compost reused, enter a final destination as described in the section for organics sent to a composter in section 6.4.6 on page 42.

For stockpiled material disposed or used as landfill cover, enter an output to landfill.

Do NOT enter any process loss, as the process loss has already been recorded in the previous return(s)

### Stockpiled Compost Like Output (CLO): Outputs sent for recycling

- In the Waste Movement Tree click on the entered Stockpile Use.
- In the Waste Details section, click on “New Output”. Select the Output Waste Type as “Compost like output”.
- Select a *Facility Type* of MBT.
- For the MBT Facility Name, **use the facility name of the composting site which the stockpiled material was originally output.**
- For stockpiled material disposed or used as landfill cover, enter an output to landfill as described above in section 4.16.8 on page 44.
- For compost reused, enter a final destination as described above in section 4.16.6 on page 42.

Do NOT enter any process loss, as the process loss has already been recorded in the previous return(s)

### For Stockpiled Refuse Derived Fuel

- Click on “New Output”.

- Select the Output Waste Type as “Refuse derived fuel”.
- Select a *Facility Type* of either:
  - Landfill (all types)
  - Incineration (all types)
  - Other Method
- For the Facility Name, again use the facility name of the site which the stockpiled material was originally output.

**Table 6. How to report waste outputs FROM “Stockpile Use”**

Output	Waste Type	Facility type	Material to report
Dry recyclables sent from storage to a re-processor	Dry Recyclate	Re-processor (see page 31 above)	Actual recyclables
Dry recyclables from storage sent to landfill or incineration	First record as Dry Recyclate to a Re-processor, then record rejects and output from the re-processor as Contamination (Gate rejects)		
Compost sent from storage to a final destination	Composting	Final Destination	N/A
Compost from storage sent to landfill or incineration	First record as Compost sent to a Composting Site, then record the rejects as an output from the Composting Site to landfill or incineration.		
Compost like output stored awaiting reuse or disposal	Compost like output	Interim Storage	Other compostable waste
Refuse derived fuel	Contamination (Process rejects)	Landfill or Incineration	Actual recyclables if known or Other material

**Table 9. How to report disposal of stockpiled waste**

Source	Waste Type	Facility type	Material to report
Dry recyclables from storage sent to landfill or incineration	First record as Dry Recyclate to a Re-processor, then record as Contamination (Gate rejects) as an output from the Re-processor		
Compost from storage sent to landfill or incineration	First record as Compost sent to a Composting Site, then record the rejects as an output from the Composting Site to landfill or incineration. Please record the Composting facility as the original facility from which the compost		
Compost like output stored awaiting reuse or disposal	Compost like output	Interim Storage	Any depending on original compost source feedstock
Refuse derived fuel	Contamination (Process rejects)	Landfill or Incineration	Other material

**Question 100 Stockpiling - Calculation of Recycling Rates**

Since 2014 only compost sent to a PAS100/110 destination and recycle sent to a final destination contributes to recycling rates. Stockpiled material will not contribute to the recycling rate (however, weight loss from the composting process will contribute to recycling).

Please note if you routinely stockpile waste outputs from a waste management site (such as compost from a composting site), the first quarter in which waste is recorded as stockpiled will result in a lower recycling rate. However, when the stockpile is recycled in subsequent quarters, the recycling rate will increase by a proportional amount.

### 6.4.11 Preparing for reuse reporting

This section explains the importance of accurately reporting waste which is prepared for reuse and provides guidance on how it should be reported. Waste which is prepared for reuse counts towards the Scottish Government Zero Waste Plan targets.

Table 1 on page 23 includes a summary of how to report the inputs to and outputs from facilities in Q100, including *Reuse* facilities.

#### Reporting drivers

The main reporting drivers are:

- To monitor impacts of preparing for reuse schemes implemented by Local Authorities and their partners
- To report against Zero Waste targets
- Recognition of “preparing for reuse” as a high priority option in the waste management hierarchy and its wider social and economic benefits
- Identify progress towards meeting the circular economy principles by driving the value of materials and products up the waste hierarchy

#### Definition

It is important to be clear about the difference between recycling and preparing for reuse, and to record data under the correct activity.

**‘Preparing for reuse’** means checking, cleaning or repairing recovery operations, by which products or components of products that have become waste are prepared so that they can be reused without any other pre-processing<sup>2</sup>.

**‘Reuse’** means any operation by which products or components that are not waste are used again for the same purpose for which they were conceived<sup>2</sup>.

**‘Recycling’** means any recovery operation by which waste materials are reprocessed into products, materials or substances whether for the original or other purposes...<sup>2</sup>

Reuse (and therefore preparing for reuse) are essentially about retaining the integrity of the item (or its components) so that it can be used again for the same purpose. Recycling processes are more destructive, breaking down items into their constituent materials so that those materials can then be shaped into new products, which could be entirely different from the input product. Table 10 presents some typical examples of the processes involved in preparing for reuse and recycling for specific materials and Appendix 2 identifies typical materials within the WasteDataFlow materials list that can be “prepared for reuse”.

---

<sup>2</sup> Source: Waste Framework Directive (2008/98/EC)



**Table 7. Examples of the processes involved in preparing for reuse and recycling for specific materials**

<b>Input product</b>	<b>Preparation for reuse</b>	<b>Recycling</b>
Textiles	Sorting, checking, cleaning of textiles so that they can be used again for their original purpose.	Cutting and shredding of textiles so that they can be used for different purpose e.g. rags, insulation etc.
WEEE	Checking, cleaning and repairing WEEE so that it can be reused for its original purpose.	Shredding of WEEE followed by recovery of metals and plastic
Furniture	Checking, cleaning, repairing item so that it can be reused as furniture	Breaking down furniture into constituent materials (e.g. textiles, wood, metal) which are then reprocessed into new products which may or may not be furniture.
Mattresses	Checking, cleaning, repairing item so that it can be reused.	Breaking down mattresses into constituent materials (e.g. textiles, metal) which are then reprocessed into new products
Floor coverings	Checking, cleaning, repairing, floor coverings so that they can be used again as floor coverings	Breaking down into constituent materials (e.g. wool fibres, rubber backing, so that they can be reprocessed into new products.
Soil		All secondary uses of soil are classed as recycling.
Rubble	Checking of bricks, concrete slabs etc. and making undamaged ones available for reuse for original purpose	Crushing / screening of rubble for use as hardcore for road construction
Wood	Checking wood, sawing off unusable sections, and making the functional sections available for reuse.	Shredding and chipping of wood to use for compost, mulch, absorbent products or as input to other process for manufacture into other products e.g. fibreboard.
Bicycles	Checking function of bicycle, repairing / replacing any broken parts and making the whole bicycle or its components available for reuse.	Sending bicycle for scrap metal recycling
Gas bottles / fire extinguishers	Checking integrity of bottle prior to refilling with gas and supplying to new customer	Sending empty gas bottle for scrap metal smelting
Tyres	Checking, cleaning and re-treading tyres so that they can be resold as tyres	Shredding of tyres
Paint	Checking tins of used paint so that they can be made available for use as-is. Mixing of used paint with other used paint to create a new paint product	

Note that components of products can be prepared for reuse – e.g. component parts of WEEE, bicycles. The salvaging of parts would also contribute towards reuse tonnage.

## Calculation of weights

Calculation of weights tonnage data is required for WasteDataFlow reporting. To obtain this data, the local authority will require key figures on total tonnage, tonnage prepared for reuse and any subsequent recycling and disposal/reject data.

Obligations to provide this data can be captured in contracting arrangements with suppliers. In some cases, like large domestic appliances and sofas, the number of reused and recycled items may be captured with an average weight applied to achieve the tonnage data. In order to ensure a consistent approach to reporting, and use of a single source of weight data, SEPA considers the FRN products weights an appropriate dataset to use to calculate the weight of items. The FRN weights can be found here; <https://reuse-network.org.uk/>

Where the reuse organisation has an authority on the weights of their products and materials. Their own weights can be applied and will be accepted.

## Final destination and rejects reporting

**Final destination:** Items being prepared for reuse, will cease to be waste when made available for reuse (and meeting all legal requirements for that reuse – e.g. PAT testing, labelling etc.). Preparing for reuse activities will therefore often be an end-destination (unless there is a multi-stage process to prepare for reuse and resale and/or redistribution, at different sites).

Some final destinations could be undertaking both recycling and preparing for reuse and local authorities need to make every effort to identify the split between each of these activities (for instance through contract conditions).

Typical organisations which provide preparing for reuse services are found within the private and third sector. These include textile reuse operations, community based reuse organisations and high street charity retailers. They undertake a number of activities such as checking, visual inspections, cleaning, repairing, testing and repackaging for resale or donation.

**Rejects:** See section 2.4 of the [Zero Waste Plan – Guidance for Local Authorities \(March 2011\)](#).

## Entering “preparing for reuse” data in WasteDataFlow

Please see sections 6.2 and 6.3 for generic guidance on how to report waste inputs and outputs in the waste movement tree in Q100 and section 6.4.3 for specific guidance on how to report waste sent to a re-processor for recycling/preparing for reuse.

If your segregated waste is going to or is exported to a facility which will prepare it for reuse, make sure you select the *Reuse* or *Exporter – reuse Facility Type* options in Q100.

If the same re-processor is used both for recycling and preparing for reuse then enter two separate entries for the same re-processor identifying the materials, tonnages and rejects associated with each process type.

## WASTEDATAFLOW USER TIPS

- When you enter data into a question always remember to **save** it before going on to another question, otherwise you will lose this data.
- You can go back to a question to review and edit the data as often as required.
- Once a question is complete, click on the 'question complete' box and save. Question 100 does not have or require a question complete box to be ticked.
- All questions should be considered. If a question is not relevant for your local authority you must put something in the comments box, even just N/A would suffice, then tick the 'question complete' box and save.
- An **asterisk (\*)** will appear in the 'Question' drop down list to show once a question is **complete**. The question can still be edited, just remember to save.
- Questions do not need to be done in order; you can select any question at any time from the 'Question' drop down list.
- To create a drop down list specific to your local authority see [section 2 of the WasteDataFlow System Manual](#) on the [WasteDataFlow](#) web.
- Rejects should only be entered once in the question they refer to, otherwise double counting will occur in the WasteDataFlow Summary.
- A breakdown of household and commercial waste is needed to satisfy EU reporting requirements and other reporting purposes such as the Waste Data Digest.
- **DO NOT use the BACK button** as the system will crash.
- '0' does not need to be put in every question, **if left blank, the system will assume zero**.
- You can set up 'selection sites' under the Management tool bar.
- If a site is not in the selection list for your drop down menu then please fill a [request form](#) to add a facility to WasteDataFlow and e-mail the form to the Waste Data Team at [wastedata.flow@sepa.co.uk](mailto:wastedata.flow@sepa.co.uk) so the new site can be added to the system. This form is currently only for preparing for reuse/recycling sites as all other sites should be available in the list.
- You can set up 'authority administration' to allow other local authorities to compare their information with yours.
- If there are any materials that are not listed in the recycling materials questions please do the following:
  - If any NON BIODEGRADABLE materials are not listed, please enter the tonnage in the 'other materials' box. In the comments section provide a description of the material.
  - If any BIODEGRADABLE materials are not listed, please enter the tonnage in the 'other compostable waste' box. In the comments section provide a description of the material.
  - If the materials are partially biodegradable please allocate the tonnage in these two sections accordingly.
  - In every case, please also give a breakdown of the tonnages and types of the 'other' materials in the comments box as there may be more than one type of material.

## 7 SPECIFIC ISSUES

### 7.1 Mixed waste collected for disposal that have materials extracted for recycling (Dirty MRF)

Put the collected tonnages in Q23 (Collected for Disposal).

In Q100 in the *Waste Movement Tree* click on *Q100: waste sent for treatment or disposal* and enter the tonnages sent to dirty MRF as described in section 6.4.9 on page 49.

Mixed waste collected for disposal includes bulky waste from special bulky waste collection uplifts that are sent to a MRF for further separation of recyclables.

### 7.2 Tromelling/Pulverisation and other material extracted for recycling (not from kerbside, bring or CA sites)

In Q100 enter the recyclate as going directly to a re-processor as described above in 6.4.3 on page 31.

### 7.3 Collection Rejects

The waste stream type “Rejects from collection” should be used for collection rejects disposed or treated. This waste stream type is available as an alternative to the “Residual waste” waste stream type, and can be used for any of the management types that would have a “Residual waste” waste stream type e.g. landfill, residual waste MRF, incineration.

The Rejects from collection waste stream type is used to record the management of rejects from waste collected for recycling. These tonnages are those that are recorded as “Tonnage collected for recycling but actually rejected/disposed” in question 10.

Q010 : Tonnes of material collected through kerbside schemes from household sources by LA or its contractors

Material	Tonnage collected for recycling	Tonnage collected for recycling but actually rejected/disposed	No. of households receiving a collection	Tonnage Collected for Reuse	Tonnage Collected for reuse but actually rejected / disposed
+ Green glass	264.100	-	-	-	-
+ Brown glass	150.910	-	-	-	-
+ Clear glass	339.560	-	-	-	-
+ Mixed glass	-	-	-	-	-
+ Books	-	-	-	-	-
+ Mixed paper & card	1280.480	-	-	-	-
+ Steel cans	-	-	-	-	-

**Figure 26. Example of collection rejects in the collection questions**

These must now be explicitly recorded in Q100. Please use the “Rejects from collection” Waste stream type when these are recorded in Q100. Please refer to Figure 27 *below* for an example of the use of this Waste stream type to record collection rejects.

In the materials section, please record the actual material if known, otherwise record the material as the materials of the collection service.

The screenshot shows a web form titled "Waste Details". The form contains the following fields and values:

- Facility/Process Type:** Non-hazardous landfill (qu52)
- Facility Name:** Stoneyhill Waste Management Ltd [change](#)
- Facility Description:** (empty text box)
- Facility Address:** Stoneyhill Quarry, Peterhead, Aberdeenshire
- Facility Licence:** PPC/N/0020010
- National Facility ID:** 8719
- Waste Stream Type:** Residual waste (selected from a dropdown menu)
- Tonnes Input:** Rejects from collection (selected from a dropdown menu, circled in red)

At the bottom of the form are two buttons: "Save" and "Cancel".

**Figure 27. Waste stream type of rejects from collection**

#### 7.4 Use of facility name “Unknown”

The facility name of all waste final destinations should be reported. However, if the name of the final destination is not known, the name of the last known destination should be reported. If the final destination or next destination of a waste output from a waste management facility is unknown then the Unknown Facility name should be used.

If the last known destination is in Scotland, then report “UNKNOWN in Scotland” (national facility ID 39531). If the last known destination is outside Scotland, or is an accredited exporter, then report as “UNKNOWN outwith Scotland” (national facility ID 39532).

The use of unknown facilities should be limited to outputs from waste management facilities whose next destination/final destination is unknown.

The next destination/final destination of wastes sent to a primary facility should always be known. Therefore, the “Unknown” option should never be used for primary facilities.

*Note: If actual final destinations are not recorded, this will impact on the quality assessment of your authority data in SEPA statistical publications.*

#### Examples of use of facility name “unknown” in question 100

**Example 1:** Use of facility name “unknown” for waste that goes from a known MRF to a known re-processor and known reuse facility, then the process rejects are landfilled at two different unknown landfills, which the re-processor / reuse facility has advised is within Scotland.

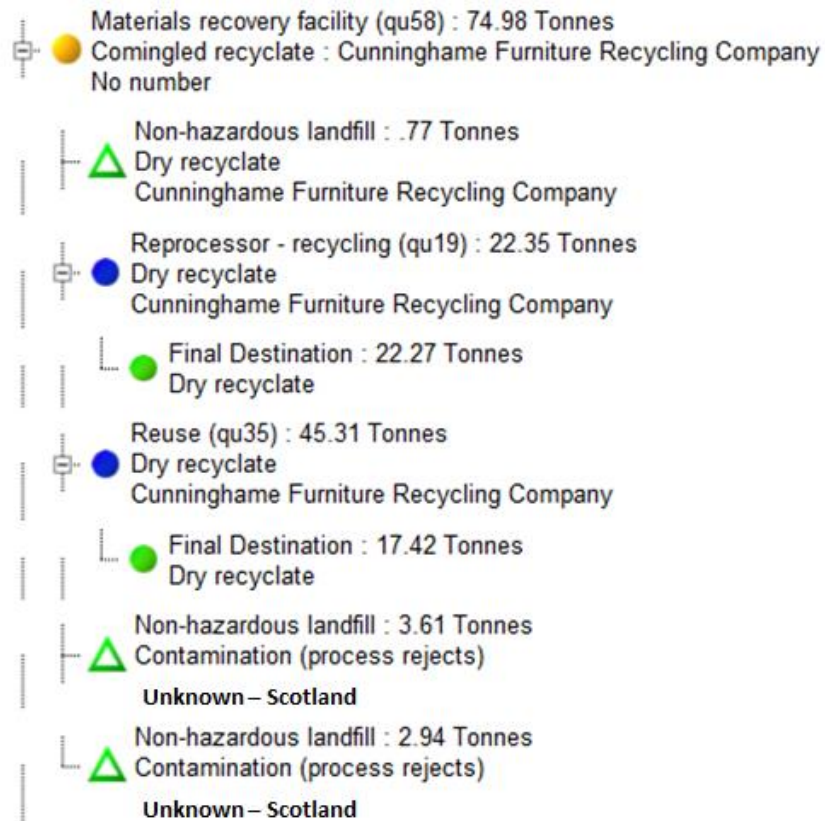

**Example 2:** Use of facility name “unknown” for waste that goes from a known MRF to a known RDF plant, then to an unknown incinerator, which the RDF Plant operator has advised is outside the UK.

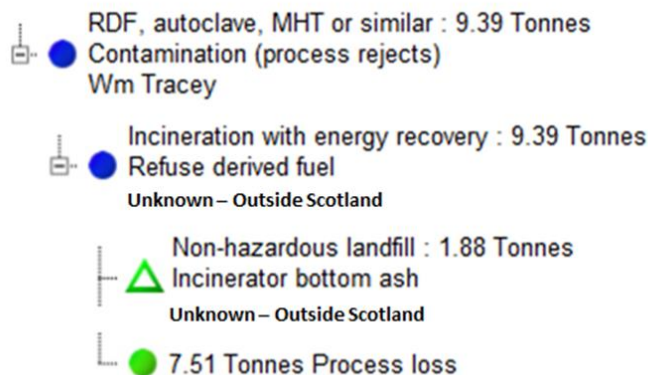

\* As the incinerator is outside the UK, it would be reasonable to assume that the bottom ash is landfilled outside the UK.

**Example 3:** Use of facility name “unknown” for waste that goes from a known MRF to a known RDF plant then to a known incinerator, and the bottom ash is landfilled at an unknown landfill, which the Incinerator operator has advised is within Scotland :



## 7.5 Allocation of household, Commercial and industrial Waste

Following the introduction of the Zero Waste Plan, SEPA undertook a survey of local authority practices for estimating the household waste in its collection. The results of the survey can be found in [the Best practice note for estimation of household waste for Scottish local authorities](#).

### Household waste

Waste from household sources denotes waste from domestic properties **only**, excluding non-domestic properties such as hospitals and nursing homes, residential hostels, residential homes, schools, universities and other educational facilities, caravan sites and campsites, self catering holiday accommodation, prisons and penal institutions, public halls, royal palaces and premises occupied by charities and used for charitable purposes.

Household waste counts towards the Zero Waste Plan 2013 and 2020 household waste recycling targets and, with the exception of construction waste, soils and plasterboard, to recycling targets specific in Article 11(2)a of the [EU Waste Framework Directive](#).

### Commercial waste

Waste from commercial sources includes:

- Waste from commercial premises, including non-domestic properties such as hospitals and nursing homes, residential hostels, residential homes, schools, universities and other educational facilities, caravan sites and campsites, self-catering holiday accommodation, prisons and penal institutions, public halls, royal palaces and premises occupied by charities and used for charitable purposes.
- Waste from industrial sources that is similar to that generated by households which includes all waste types under [European Waste Catalogue](#) Code 20 and some wastes under Codes 15 and 19.
- Waste from industrial sources that is mixed with the waste from commercial premises or household sources as part of the same waste collection round.

Commercial waste together with household waste form part of the Local Authority Collected Municipal Waste (LACMW) and will count towards the [Zero Waste Plan](#) 2025 70% recycling target for all waste.

## Industrial waste

Waste from industrial sources is industrial waste taken for disposal or treatment separately from any other waste, excluding waste from industrial sources that is similar to households which should be reported under commercial waste (see the commercial waste section above).

Industrial waste together with household and commercial waste form part of the Local Authority Collected Waste (LACW) and will count towards the 2025 all waste 70% recycling/composting target (with the exception of asbestos separately collected).

### Collected for Disposal (Q23) Waste Categories:

Table 8 below identifies the waste categories that are available in WasteDataFlow for reporting of waste collected for disposal or mixed waste collected for further treatment, their associated waste sources, and applicable [Zero Waste Plan](#) targets.

**Table 8. WasteDataFlow waste categories, associated waste source and applicable targets**

Waste category	Associated waste source	Counts towards household waste target?	Counts towards 2025 all waste target?
Collected household waste : Regular Collection	Household	Yes	Yes
Collected household waste : Street Cleaning	Commercial	No	Yes
Collected household waste : Bulky Waste	Household	Yes	Yes
Collected household waste : Other	Household	Yes	Yes
Civic amenity sites waste : Household	Household	Yes	Yes
Civic amenity sites waste: Non Household	Commercial	No	Yes
Collected gully emptyings	Commercial	No	Yes
Collected non-household waste : Highways waste	Industrial	No	Yes
Collected non-household waste : Construction and Demolition	Industrial	No	Yes
Collected non-household waste : Grounds Waste	Commercial	No	Yes
Collected non-household waste : Commercial & Industrial	Commercial	No	Yes
Collected non-household waste : Other	Commercial	No	Yes
Separately collected healthcare waste	Industrial	No	Yes
Beach cleansing	Commercial	No	Yes
Waste Arising from clearance of fly-tipped materials	Commercial	No	Yes
Asbestos Waste separately collected	Industrial	No	Yes
Other collected waste	Industrial	No	Yes

## 7.6 Collecting data from waste contractors

To ensure consistency of data that is being requested by local authorities of their waste contractors employed, we recommend use of the [waste data contractor report template](#). This template was



produced by SEPA and provides background information on why the data is being requested, in addition to what data is required.

### **7.7 How to record wood sent for recycling or recovery**

Where wood is used as “biomass”, this should be recorded as incinerated.

Where wood is recorded as recycled (i.e. recorded as sent to a reprocessor) please ensure that evidence has been obtained from the destination facility that confirms the wood sent has been recycled. Where the destination facility is unknown, or the final management of the wood has not been confirmed, record the wood as managed by incineration.

## Appendix 1. Definitions

**BSI PAS 100 / 110** – a national compost/digestate benchmark that specifies the minimum requirements for the process of composting/anaerobic digestion, the selection of material from which compost/digestate is made, and standards for the compost/digestate product quality. PAS 100 is applicable to composting facilities while PAS 110 is applicable to anaerobic digestion facilities.

**Compost** - waste recycled by biological treatment through composting at a composting plant.

**Compost like output:** organic outputs following the Mechanical biological treatment of residual waste.

**Contamination (process rejects):** waste that is rejected for disposal. (If waste is sent to a reprocessor then it would not be classed as a reject)

**Contamination (gate rejects):**

**Digestion-** waste recycled by biological treatment through digestion at an anaerobic digestion facility.

**Dry Recyclate:** waste that is free from contaminants leaving clean materials suitable for entry into the recycling or reuse chain.

**Household waste** – waste generated by households (see full definition in Paragraph 1.2 of the *Zero Waste Plan - guidance for local authorities* on the [WasteDataFlow web site](#)).

**Preparing for reuse:** means checking, cleaning or repairing recovery operations, by which products or components of products that have become waste are prepared so that they can be reused without any other pre-processing<sup>3</sup>.

**Process loss:** losses from treatment due to fugitive emissions, including biological degradation and moisture loss.

**Recycling:** means any recovery operation by which waste materials are reprocessed into products, materials or substances whether for the original or other purpose.

**Reuse:** any operation by which products or components that are not waste are used again for the same purpose for which they were conceived

**Refuse derived fuel (RDF)** – waste separated from residual municipal solid waste with a calorific value suitable for use as a fuel in combustion processes.

**Source Segregated Recyclate:** dry recyclate that has been separated for the purpose of recycling or reuse.

---

<sup>3</sup> Source: Waste Framework Directive (2008/98/EC)

## Appendix 2. Typical materials that can be “prepared for reuse”

Table 9. Typical materials that can be prepared for reuse

Green glass		Aluminium foil	
Brown glass		Aerosols	
Clear glass		Bric-a-brac	X
Mixed glass		Cardboard beverage packaging	
Paper		Fire extinguishers	X
Card		Gas bottles	X
Books	X	Ink & toner cartridges	X
Mixed paper & card		Mattresses	X
Steel cans		Paint	X
Aluminium cans		Textiles & footwear	X
Mixed cans		Textiles only	X
Plastics		Footwear only	X
Mixed Plastic Bottles		Video tapes, DVDs and CDs	X
PET [1]		Yellow Pages	
HDPE [2]		Other materials	X
PVC [3]		Bicycles	X
LDPE [4]		Carpets	X
PP [5]		Absorbent Hygiene Products (AHP)	
PS [6]		Co-mingled materials	
OTHER PLASTICS [7]			
Green garden waste only			
Waste food only			
Mixed garden and food waste			
Wood for composting			
Other compostable waste			
Wood	X		
Chipboard and MDF	X		
Composite wood materials			
WEEE - Large Domestic App	X		
WEEE - Small Domestic App	X		
WEEE - Cathode Ray Tubes			
WEEE - Fluorescent tubes and other light bulbs			
WEEE - Fridges & Freezers	X		
Other Scrap metal			
Automotive batteries			
Post-consumer, non-automotive batteries			
Car tyres	X		
Van tyres	X		
Large vehicle tyres	X		
Mixed tyres	X		
Furniture	X		
Rubble	X		
Soil			
Plasterboard			
Vegetable Oil			
Mineral Oil			

### Appendix 3. Household Waste Statistics

Each year SEPA publish waste statistics using data provided by Scottish local authorities in WDF. The statistics can be found on [SEPA's web site](#) and on [Scotland's Environment Web](#). This data is also used for reporting to the EU in accordance with the [Waste statistics regulations](#) and [Waste Framework Directive](#).

The waste categories defined in the EU [Waste statistics regulations](#) are currently used by SEPA for all National and EU reporting. The mapping of WasteDataFlow categories into the statistical reporting categories are specified in the table below.

**Table 10. Statistical waste categories**

WasteDataFlow category	Mapping Ratio	Statistical waste category
Absorbent Hygiene Products (AHP)	1	Health care and biological wastes
Aerosols	1	Chemical wastes
Aggregates	1	Soils
Aluminium cans	1	Metallic wastes, non-ferrous
Aluminium foil	1	Metallic wastes, non-ferrous
Automotive batteries	1	Batteries and accumulators wastes
Bicycles	1	Discarded vehicles
Books	1	Paper and cardboard wastes
Bric-a-brac	1	Household and similar wastes
Brown glass	1	Glass wastes
Car tyres	1	Rubber wastes
Card	1	Paper and cardboard wastes
Composite food and beverage cartons	1	Mixed and undifferentiated materials
Carpets	1	Textile wastes
Chipboard and mdf	1	Wood wastes
Clear glass	1	Glass wastes
Co-mingled materials	1	Mixed and undifferentiated materials
Composite wood materials	1	Wood wastes
Fire extinguishers	1	Chemical wastes
Footwear only	1	Textile wastes
Furniture	1	Household and similar wastes
Gas bottles	1	Chemical wastes
Green garden waste only	1	Vegetal wastes
Green glass	1	Glass wastes
HDPE [2]	1	Plastic wastes
Incinerator Bottom Ash	1	Combustion wastes
Ink & toner cartridges	1	Chemical wastes
Large vehicle tyres	1	Rubber wastes
LDPE [4]	1	Plastic wastes
Mattresses	1	Household and similar wastes
Mineral Oil	1	Used oils
Mixed cans	1	Metallic wastes, mixed ferrous and non-ferrous
Mixed garden and food waste	0.75	Vegetal wastes
Mixed garden and food waste	0.25	Animal and mixed food waste
Mixed glass	1	Glass wastes
Mixed paper & card	1	Paper and cardboard wastes
Mixed Plastic Bottles	1	Plastic wastes
Mixed Plastics	1	Plastic wastes
Mixed tyres	1	Rubber wastes

<b>Other compostable waste</b>	1	Vegetal wastes
<b>Other materials</b>	1	Mixed and undifferentiated materials
<b>OTHER PLASTICS [7]</b>	1	Plastic wastes
<b>Other Scrap metal</b>	1	Metallic wastes, mixed ferrous and non-ferrous
<b>Paint</b>	1	Chemical wastes
<b>Paper</b>	1	Paper and cardboard wastes
<b>PET [1]</b>	1	Plastic wastes
<b>Plasterboard</b>	1	Mineral waste from construction and demolition
<b>Post consumer, non automotive batteries</b>	1	Batteries and accumulators wastes
<b>PP [5]</b>	1	Plastic wastes
<b>PS [6]</b>	1	Plastic wastes
<b>PVC [3]</b>	1	Plastic wastes
<b>Rubble</b>	1	Mineral waste from construction and demolition
<b>Soil</b>	1	Soils
<b>Steel cans</b>	1	Metallic wastes, ferrous
<b>Textiles &amp; footwear</b>	1	Textile wastes
<b>Textiles only</b>	1	Textile wastes
<b>Van tyres</b>	1	Rubber wastes
<b>Vegetable Oil</b>	1	Animal and mixed food waste
<b>Video tapes, DVDs and CDs</b>	1	Plastic wastes
<b>Waste food only</b>	1	Animal and mixed food waste
<b>WEEE - TVs &amp; Monitors</b>	1	Discarded equipment (excluding discarded vehicles, batteries and accumulators wastes)
<b>WEEE - Flourescent tubes and other light bulbs</b>	1	Discarded equipment (excluding discarded vehicles, batteries and accumulators wastes)
<b>WEEE - Fridges &amp; Freezers</b>	1	Discarded equipment (excluding discarded vehicles, batteries and accumulators wastes)
<b>WEEE - Large Domestic App</b>	1	Discarded equipment (excluding discarded vehicles, batteries and accumulators wastes)
<b>WEEE - Small Domestic App</b>	1	Discarded equipment (excluding discarded vehicles, batteries and accumulators wastes)
<b>Wood</b>	1	Wood wastes
<b>Wood for composting</b>	1	Wood wastes
<b>Yellow Pages</b>	1	Paper and cardboard wastes
<b>Metals from Incinerator Bottom Ash</b>	1	Metallic wastes, mixed ferrous and non-ferrous
<b>Residual Waste</b>	1	Household and similar wastes